

FLUKE®

Calibration

5080/CAL

Calibration Software

Users Manual

Table of Contents

Title	Page
Introduction.....	1
Safety Information	2
System Requirements	3
Installation	3
Security	3
Main Menu.....	3
How to Choose a Language	3
Samples Included with the Software.....	4
Records Management	4
Inventory Data Rules	5
How to Search for an Asset by Asset Number	5
How to Search for an Asset by Other Data	5
Locating Groups of Assets	6
Calibration Records	6
How to Create Calibration Procedures	7
Using the Procedure Designer	7
Test Types	8
Test Modes	8
Auxiliary Settings.....	9
Run-Time Control	9
Creating a Fluke 77 Performance Procedure.....	9
Comments	10
Messages	10
Images and Documents	10
Voltage Tests	11
Ohms Tests	14
Manual Tests	15
Manual Numeric Tests	15
Manual Text Tests.....	16
Procedure Rules.....	17
Other Procedure Design Tools	17
Test Limits	18
AutoPro Wizard	18
Performing a Calibration	20
Post-Calibration Screen	23
How to Run Reports	25

How to Create Reports.....	26
Calibration Certificates.....	26
How to Add Database Fields to a Report.....	27
How to Add a List of Calibration Standards.....	29
How to Add Calibration Results.....	30
How to Save the Report.....	32
Data Reports.....	32
How to Filter a Report.....	33
How to Sort a Report.....	34
Other Report Layout Tools.....	35
Data Export Tool.....	36
Procedure Import and Export Function.....	36
How to Export Calibration Procedures.....	36
How to Import Calibration Procedures.....	37
Database Backup.....	38
Restore from a Backup.....	38
Options.....	38
Communication with the 5080A Calibrator.....	38
How to Install the USB to Serial driver.....	39
How to Configure the 5080A to Communicate with the 5080/CAL Software.....	39
A Oscilloscope Calibration.....	A-1
Introduction.....	A-1
How to Make Oscilloscope Procedures.....	A-1
Vertical Gain Accuracy.....	A-1
Rise Time Calibration.....	A-2
Scope Rise Time and the Observed Rise Time.....	A-3
Actual Scope Rise Time.....	A-3
Bandwidth Testing.....	A-4
Bandwidth Measurements on Digital Oscilloscopes.....	A-5
Horizontal Timing Accuracy.....	A-7
Reference Material.....	A-7
B Megohm Calibration.....	B-1
Introduction.....	B-1
Leakage Tests.....	B-1
Short Circuit Tests.....	B-3
High Resistance values.....	B-3
Low Voltage Ohm Source.....	B-3
C Database Fields.....	C-1
D Results Table.....	D-1

List of Tables

Table	Title	Page
1.	Records Screen Controls	5
2.	DC Voltage Test.....	12
3.	AC Voltage Test.....	14
4.	Resistance Test.....	15
A-1.	Oscilloscope Calibration Modes of Operation	A-1
B-1.	Megohm Functions.....	B-1
B-2.	Insulation Resistance Accuracy Test.....	B-2
C-1.	Inventory Data Fields	C-1
C-2.	Calibration Data Fields	C-1
C-3.	Results Data Fields.....	C-2
D-1.	Test Results	D-1
D-2.	Column Descriptions for Test Results Table	D-2

List of Figures

Figure	Title	Page
1.	5080/CAL Screen.....	3
2.	Records Screen.....	4
3.	Search Fields.....	6
4.	Calibration Record.....	6
5.	Procedure Designer Screen.....	7
6.	Test Type Selection.....	8
7.	Test Mode Selection.....	8
8.	Auxiliary Settings.....	9
9.	Test Setup Graphic for Fluke 77 Series III.....	10
10.	Test Procedure for Fluke 77 Series III Multimeter.....	11
11.	Completed DC Voltage Test for Fluke 77.....	12
12.	Procedure Save Dialog.....	13
13.	Fluke 77 Test Procedures with Auxiliary Settings.....	14
14.	Fluke 77 Test Procedure.....	17
15.	Limit Calculator.....	18
16.	AutoPro Wizard Form.....	18
17.	AutoPro Wizard Created Test Steps.....	19
18.	AutoPro Wizard Settings with Step Size Set.....	19
19.	Test Steps Created with Setting Step Size.....	20
20.	Select Item and Procedure Screen.....	20
21.	Calibration Screen.....	21
22.	Calibration Screen with Test Results.....	22
23.	Resized Calibration Screen.....	22
24.	Post-Calibration Screen.....	23
25.	Report Screen.....	24
26.	Reports Screen.....	25
27.	Item and Calibration Date Selection Screen.....	26
28.	Certificate Designer Screen.....	27
29.	Adding a Database Field to a Report.....	28
30.	Completed Certificate of Calibration Design.....	29
31.	Calibration Standards Insertion Screen.....	29
32.	Calibration Standards List.....	30
33.	Calibration Results Field Selection.....	30
34.	Calibration Results Table.....	30
35.	Certificate of Calibration Report Template.....	31
36.	Completed Certificate Report.....	32

37.	Save Report Screen	32
38.	Report Details Selection.....	33
39.	Inventory Report Template	33
40.	Report Details Screen.....	34
41.	Start and End Date Dialog Box	35
42.	Recall Report Sorted by Due Date	35
43.	Data Export Screen	36
44.	Procedure Export Screen.....	37
45.	Import Procedure Screen.....	37
46.	Port Configuration Dialog Box	39
A-1.	Complete Vertical Gain Calibration Procedure.....	A-2
A-2.	Default Auxiliary Settings.....	A-2
A-3.	Scope Display with 2 V p-p at 1000 HZ	A-2
A-4.	Rise Time Calculator.....	A-3
A-5.	Scope Display of Rise Time	A-4
A-6.	Calibration Procedure for Bandwidth Test.....	A-4
A-7.	Bandwidth Test at 200 MHz	A-5
A-8.	Scope Display for Bandwidth Test.....	A-5
A-9.	Bandwidth Test on Digital Scope at 50 kHz	A-6
A-10.	Bandwidth Test at 100 MHz	A-6
A-11.	Bandwidth Test with Manual Entry	A-6
A-12.	Horizontal Timing Accuracy Display	A-7
B-1.	Fluke 1577 Calibration Procedure.....	B-2
B-2.	Short Circuit Test Steps	B-3
B-3.	High Resistance Values Calibration Steps	B-3
B-4.	Low Voltage Ohm Source Calibration Steps	B-3

Introduction

The Fluke 5080/CAL (Calibration Software) is a semi-automated paperless calibration program used with the Fluke 5080A Calibrator. It is a stand-alone, easy-to-use solution for asset management, calibration and reporting.

The software works on these product families:

- Analog meters
- Panel meters
- Digital multimeters
- Watt meters
- Clamp meters (with coil accessory)
- Megohm meters (optional)
- Oscilloscopes to 200 MHz (optional)

The Calibration Software has these features:

- 5080/CAL speeds calibration through control of the calibrator
- Automatically makes calibration records for each calibration performed
- Make Reports easily without training or assistance
- A Procedure Designer to quickly make procedures for your workload
- Keep inventory and calibration records in a Microsoft SQL Server database
- Set language as English, French, German, Spanish, Italian, Russian, Japanese, or Simplified Chinese.

Safety Information

This manual contains information, warnings, and cautions that must be followed to ensure safe operation and to maintain the Calibrator in a safe condition.

Warning

To prevent possible electrical shock, fire, or personal injury:

- **Never use a screen saver when using the Run Time application. Screen savers will hide the high voltage safety symbol. The Run Time program controls the 5080A Calibrator and can cause it to output dangerous voltage levels. The high voltage safety symbol indicates when dangerous voltage is present.**
- **Use interconnect wiring and adapters rated for the highest voltage and current levels carried.**
- **Never touch exposed conductive portions of signal interconnect wiring, even after instruments have been turned off.**
- **Only touch the insulated portion of a connector. First disconnect the interconnect wiring at the source, then at the measurement side.**
- **Always use insulated adjustment tools.**
- **If the calibration program is abnormally terminated, verify that the front panels of source instruments indicate standby mode.**
- **When writing procedures, make sure that procedures minimize the time during which dangerous voltages are applied.**

System Requirements

The recommended requirements for installation are:

- Microsoft XP SP2, Vista, or Windows 7 operating system
- 2 Gigabytes of available hard disk space for Microsoft.NET Framework
- 50 Megabytes for 5080/CAL software
- 1024 x 768 or higher resolution monitor
- Microsoft.NET framework version 3.0 or later installed

Installation

To install the Calibration Software, execute 5080Cal Setup.exe. Fluke recommends that you install 5080/CAL in the default directory:

```
C:\Program Files\Fluke\5080CAL
```

Security

To perform a calibration you must connect the 5080A Calibrator to a PC and turn-on both. Record maintenance, reporting and procedure creation is possible without a connection between the 5080A and a PC.

Main Menu

The Calibration Software screen in Figure 1 shows a menu system and a toolbar. The three primary software functions are accessed from the toolbar or the Tools menu. The Tools menu lets you access other functions described in this manual.

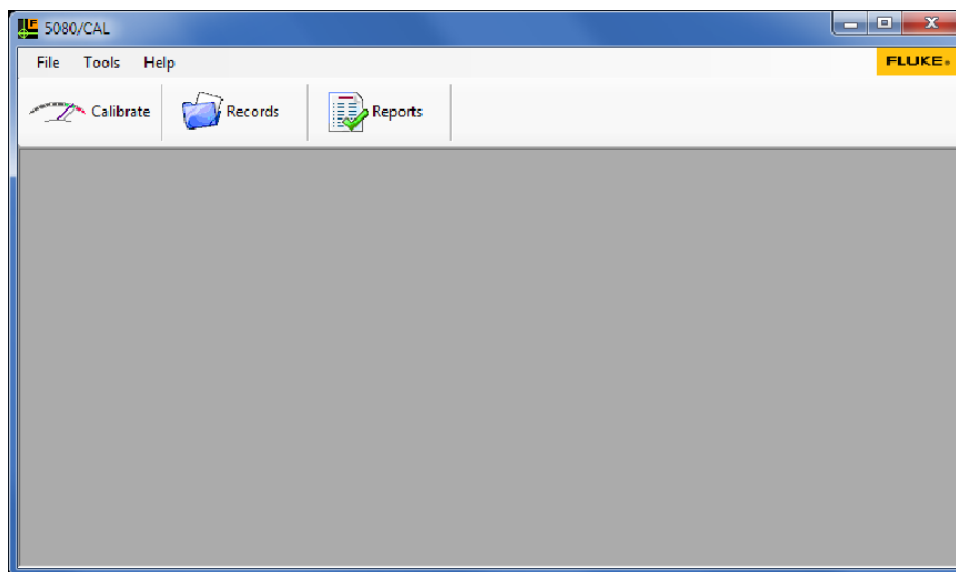

Figure 1. 5080/CAL Screen

gji01.bmp

You access the run-time tools where calibrations are done through the Calibrate button. The Records button shows the Records screen where the inventory and calibration records can be added, updated, or removed. You access system reports through the Reports button.

How to Choose a Language

You can set the language for the Calibration Software through the language tool. You can set the language to English, French, German, Italian, Spanish, Russian, Japanese, or Simplified Chinese. By default, the system displays English. To change the language, click **Tools**, point to **Language** from the main menu, and then the language.

Samples Included with the Software

The Calibration Software includes twenty sample assets to help you learn to use the system and get started. You can remove these when they are no longer necessary. Some Calibration Certificates and data reports are included. Several calibration procedures are also included.

Records Management

The records screen in Figure 2 is used to add, edit, or remove inventory and calibration records. To access the screen, click on  Records, or click **Tools** and then point to **Record**. You can also push **F3** to open the Records screen.

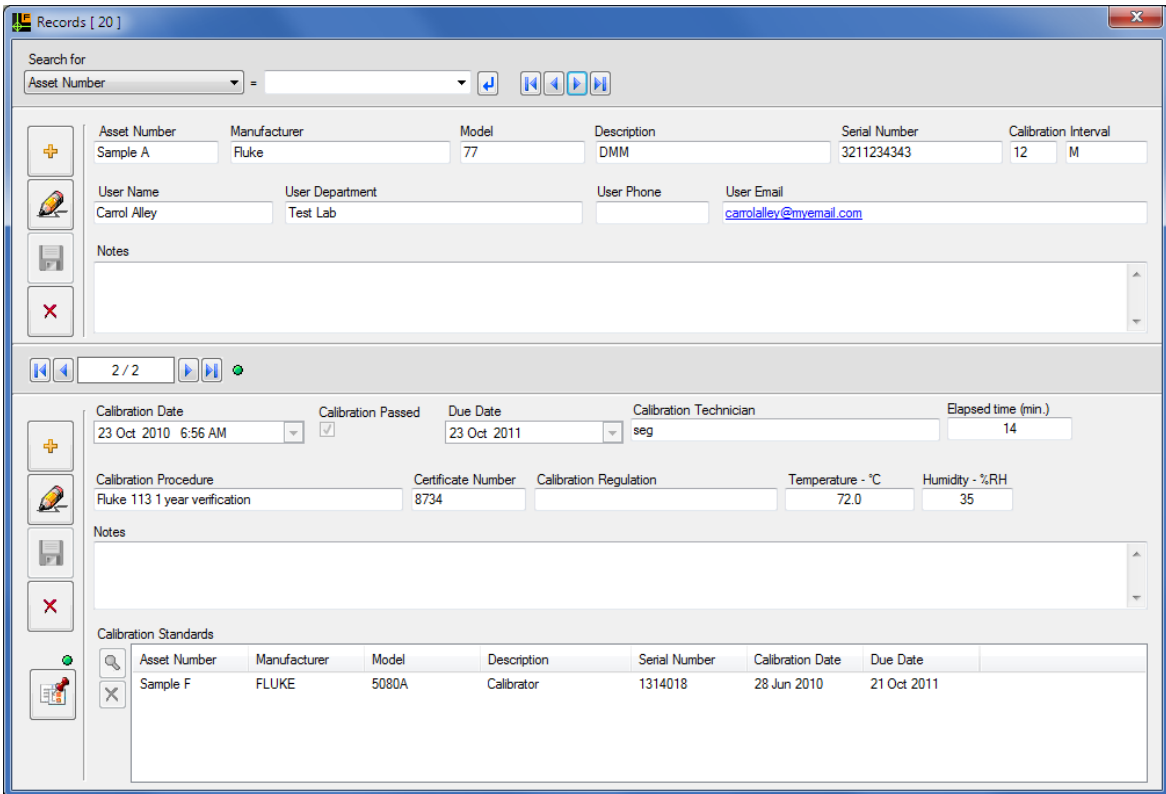

Asset Number	Manufacturer	Model	Description	Serial Number	Calibration Interval
Sample A	Fluke	77	DMM	3211234343	12 M

User Name	User Department	User Phone	User Email
Carrol Alley	Test Lab		carrolalley@mvemail.com

Calibration Date	Calibration Passed	Due Date	Calibration Technician	Elapsed time (min.)
23 Oct 2010 6:56 AM	<input checked="" type="checkbox"/>	23 Oct 2011	seg	14

Calibration Procedure	Certificate Number	Calibration Regulation	Temperature - °C	Humidity - %RH
Fluke 113 1 year verification	8734		72.0	35





Asset Number	Manufacturer	Model	Description	Serial Number	Calibration Date	Due Date
Sample F	FLUKE	5080A	Calibrator	1314018	28 Jun 2010	21 Oct 2011

Figure 2. Records Screen

gji02.bmp

The screen has three sections. Use the top section to search, sort, and navigate through inventory items. The middle section contains fields of data about an item that includes the current user of the item. These are the inventory fields. The bottom section contains the calibration records and the standards used during a calibration. Table 1 describes how to use each control.

Table 1. Records Screen Controls

Control	Description
	Adds a new inventory record. All yellow fields must be filled in. To cancel, click Add again.
	Edit a record. When fields are edited, their background color changes to green. To cancel, click edit again.
	Saves a record.
	Removes an inventory record. This removes all calibration records for this item as well.
	Show detailed calibration results.

Inventory Data Rules

The rules below apply to the inventory records:

- The Asset Number cannot be duplicated. Choose an identification that is unique.
- Other than the notes field, all fields are 100 characters in length. The notes field can contain a maximum of 1000 characters. The Calibration Software is a Unicode system and can contain characters from all languages.
- Required fields have a yellow background and must contain data before you can save.
- A calibration interval of “0” means that an item is not calibrated.
- The interval types include D for days, W for weeks, and M for months.
- The User Email field can be used to send email to the user. With a valid email address, the field displays as a blue hyperlink with an underline. When the hyperlink is clicked, the computer email system shows and sends a message to that person.



How to Search for an Asset by Asset Number

To find an item by asset Number, set the **Search for** list box in the upper-left corner of the records screen to **Asset Number**. Type or bar-code the asset number into the text box and push enter or click . The data about the item is shown in the inventory and calibration fields.

How to Search for an Asset by Other Data

You can search and sort by Asset number, Manufacturer, Model, Description, User Name and User department.

To start a search:

1. Click  in the **Search for** field and point to a field.
2. Type the text for the search in the field.
3. Click on .





The example in Figure 3 finds all Fluke 87 Multimeters. The database contains 2 records for Fluke 87 Multimeters. Use  and  to navigate from the first to the last.



Figure 3. Search Fields

Locating Groups of Assets

To speed up the sort and search function, double-click the Manufacturer, Model, Description, User Name, or User department fields. This sorts the records by that field, and moves to the first item in the group. In this example, if the Manufacturer field is double-clicked, and the name in the field is "Fluke," the records will be sorted by manufacturer name and the first Fluke item shows in the display. Use  and  to navigate through these records. The number of items in the group shows at the top of the screen.

Calibration Records

Like inventory records, you can add, edit, or remove calibration records. As shown in Figure 4, the item was calibrated two times. Use the four blue arrow navigation buttons to review the calibration history. Calibration records are added, edited or removed with the four buttons on the left side of the screen. The green dot is an indicator that the most recent calibration record is shown in the display. Each calibration record can list a maximum of five calibration standards that were used during the calibration. To show the test results added to the record at calibration run-time, click the lower-left button. The green dot is an indicator that there are calibration results for this calibration. Calibration and due dates are input directly or by a drop-down calendar.

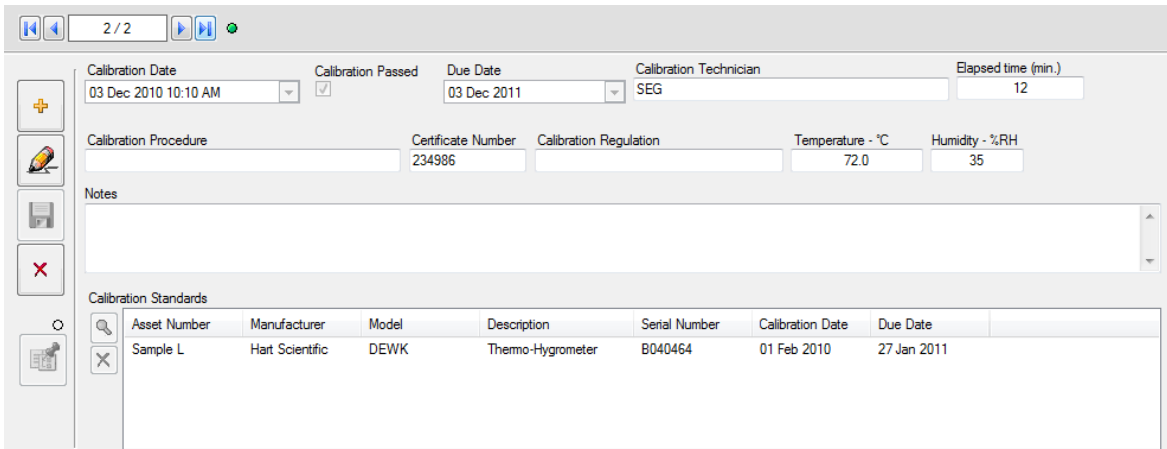

Figure 4. Calibration Record

When you add a new calibration record, the calibration date defaults to the current date. If the calibration passes, the calibration due date is set to the calibration date plus the calibration interval.

These rules apply to the calibration records:

- An Inventory item can have more than one calibration record.
- The calibration record pointer is in the upper-left side of the calibration screen. It shows which of the items calibration records are in the display.
- Use the blue arrow buttons to navigate through the records. The dot to the right of the arrow buttons is green when the most recent calibration record is shown.
- A calibration record contains a maximum of five calibration standards for calibration procedures.
- Text fields contain a maximum of 100 characters. The Notes field contains a maximum of 1000 characters.

How to Create Calibration Procedures

Use the procedure designer to make new or change calibration procedures or change existing one. A procedure is made up of messages and 5080A commands. A new line is made for each message or test. The procedure is a template that is used when the procedure is executed.

Using the Procedure Designer

To open the Procedure Designer screen shown in Figure 5, click **Tools** from the main menu then point to **Procedure Designer** or push **F8**.

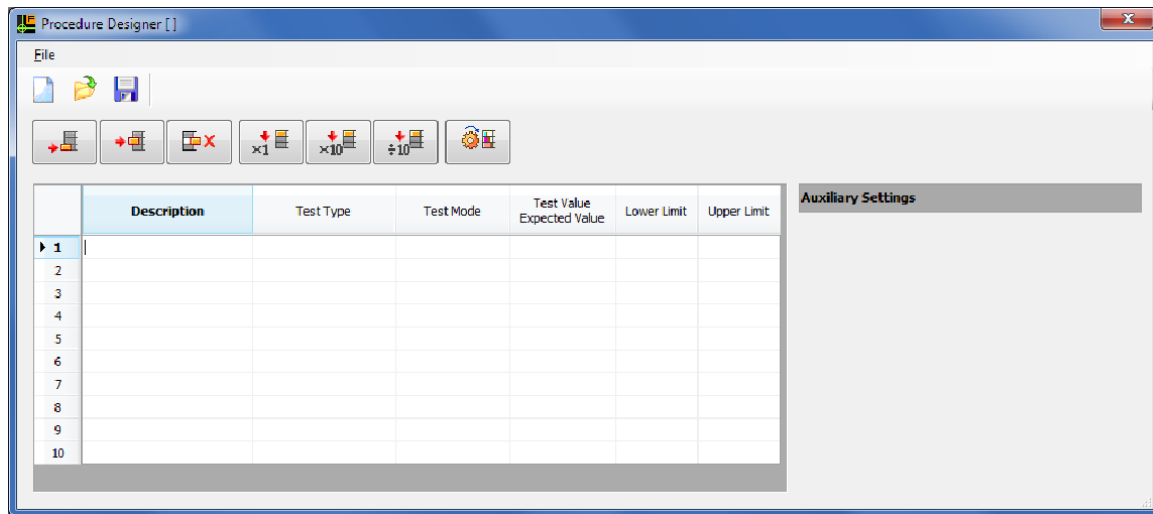

Figure 5. Procedure Designer Screen

gji08.bmp

To create a test, select the Test Type column. When it is selected, the Test Types are listed in a drop down list shown in Figure 6.

	Description	Test Type	Test Mode	Test Value Expected Value	Lower Limit	Upper Limit
1						
2						
3		5080A V-Ω-A				
4		5080A Scope				
5		5080A Power				
6		5080A Megohm				
7		Manual Test				
8		Message				
9		Comment				
10		Show Document				

gji76.bmp

Figure 6. Test Type Selection

Test Types

Select a Test Type:

- **5080A V-Ω-A** for tests that require volts, ohms or amps.
- **5080A Scope** for signals generated by the 200 MHz oscilloscope option. (optional)
- **5080A Power** when calibrating wattmeters.
- **5080A Megohm** for megohm, leakage, and other safety testers. (optional)
- **Manual Test** when performing non-5080A tests.
- **Message** to display an operator message when the procedure is run.
- **Comment** to insert a comment or note into the procedure. This will not be seen when the procedure is run.
- **Show Document** to display text, graphic, or multi-media files that can provide additional information or instruction about the calibration at run time.

Test Modes

After a Test Type is selected, the Test Mode list is shown, see Figure 7. This list is context sensitive and displays choices that are appropriate for the selected Test Type. In this example the 5080A provides the AC Amps for test. Next, enter the test value and test limits.

	Description	Test Type	Test Mode	Test Value Expected Value	Lower Limit	Upper Limit
1		5080A V-Ω-A	AC Amps	5	4.5	5.5
2			DC Volts			
3			AC Volts			
4			DC Amps			
5			AC Amps			
			Fixed Ohms			

gji77.bmp

Figure 7. Test Mode Selection

Auxiliary Settings

Each Test Mode has Auxiliary Settings that control the 5080A and 5080/CAL during a test. The Auxiliary Settings window for AC Amps is shown in Figure 8.

Auxiliary Settings	
Frequency	60
Current Terminals	Aux-20A
Current Coil	None
L-Comp	<input type="checkbox"/>
Low tied to earth	<input type="checkbox"/>
Run-Time Control	
Store reading as offset	<input type="checkbox"/>
Apply offset to reading	<input type="checkbox"/>
No evaluation performed	<input type="checkbox"/>

gji87.bmp

Figure 8. Auxiliary Settings

Enter or select the settings for each test. The *5080A Operators Manual* describes these settings in more detail.

Run-Time Control

The Auxiliary Settings window provides additional run-time controls that can be enabled by checking them.

- **Store reading as offset**, when checked, will store the reading. It will be applied to a later test. This capability is typically used in ohms test to compensate for lead resistance.
- When the **Apply offset to reading** is checked, the stored offset will be algebraically added to the Test Value / Expected Value
- When **No evaluation performed is checked**, a test is performed, but there is no pass/fail evaluation. The capability can be used when storing a reading as an offset. It is also used on tests where the 5080A needs to step the test signal slowly to the final value to prevent tripping the output to standby on high burden loads.

Creating a Fluke 77 Performance Procedure

This section is about how to make a performance test procedure for the Fluke 77 Series III Digital Multimeter. The procedure comes from version 1 of the *Fluke 77 Series Service Manual*, dated November 1999. This performance test is easy to follow and is a good how-to-learn procedure.

Click **Tools** from the main menu then point to **Procedure Designer**. Or, push **F8** to open the new procedure screen, see Figure 5.

The new procedure screen has rows for 10 tests. Add more rows through the buttons above the entry grid.

A dc voltage test is specified first. The dc voltage test description for the Fluke 77 multimeter starts on page 3 of the service manual. The steps are:

1. Set the UUT function switch to VDC. Connect the DC Voltage Calibrator output to the **VΩ→** and COM input terminals of the UUT.
2. Refer to Table 2 to set the DC Voltage Calibrator for the output shown in steps 1 through 4 only. Make sure that the UUT display reading is within the limits.
3. Set the DC Voltage Calibrator for an output of +300 mV. Set the UUT to the 300 mV function. Make sure that the UUT display reading is within the limits, see Table 2 (step 5).

Comments

To add comments:

1. Click on the row 1 Test-Type column.
2. From the drop-down window, choose **Comment**.
3. In the Test mode column, type a message. For example:

This procedure is from Rev 1 of the Fluke model 77 service manual dated 11/99.

Comments are for the procedure writer only and are not shown when the procedure executes.

Messages

To have the Calibration Software show a message to the user:

1. Click in the Row 2 Test Type column.
2. From the drop-down window, choose **Message**.
3. Type a message. For example:

Set the UUT function switch to VDC and connect the Calibrator output to the Volt-Ohm terminals and COM input terminals of the model 77.

Images and Documents

You can use a graphic image of the 5080A and a Model 77 as an alternative to a text message, see Figure 9.

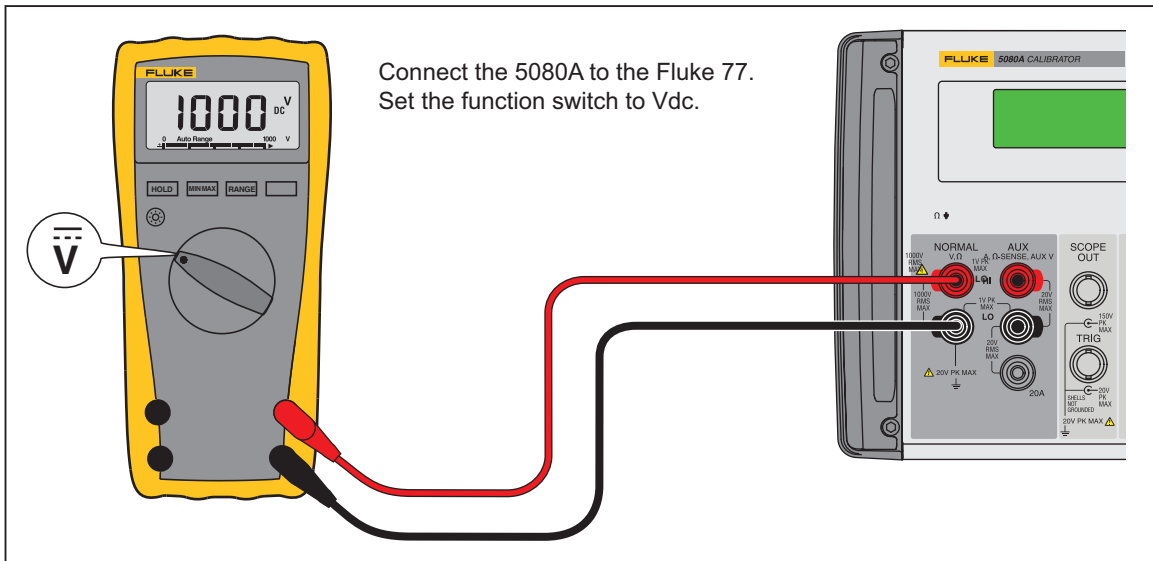

Figure 9. Test Setup Graphic for Fluke 77 Series III

gji10.eps

To add a graphic to the procedure:

1. Click on the Row 4 Test Type column.
2. From the drop-down window, choose **Show Document**.
3. Click the button on the right-side of the row and navigate to the image to show on the display.
4. Click **Open**.

When the procedure executes, the graphic in Figure 9 shows in the display. The Calibration Software accepts JPG, GIF, JPEG, TIFF, RAW, PNG and BMP file formats. The calibration software also accepts the document formats DOC, PDF, RTF, and TXT and multimedia files in AVI, MPG, MP3, MP4, MPEG, WAV, and WMF format. This lets you show static images, documents, and dynamic multimedia data for connection information and instruction.

These steps result in the procedure shown in Figure 10.

	Description	Test Type	Test Mode	Test Value Expected Value	Lower Limit	Upper Limit
1						
2		Comment	This procedure is from Rev 1 of the Fluke model 77 service manual dated 11/99			
3		Message	Set the UUT function switch to VDC, and connect the Calibrator output to the Volt-Ohm terminals and COM input terminals of the model 77			
4		Show Document	5080_77.bmp			
5						
6						
7						
8						
▶ 9						
10						

gji11.bmp

Figure 10. Test Procedure for Fluke 77 Series III Multimeter

Note

Adjust the row height to see the complete message. Click the bottom of the row by the row number and pull the row to a new height.

Voltage Tests

Table 2 shows five calibration points in the dc voltage test. To add the first four steps:

1. Click in the Test Types column on a new row.
2. Click on 5080 V-Ω-A from the drop-down list in the Test Mode column and select dc volts.
3. Type the test voltage into the Test Value column. In this example, type in 2.7.
4. Type 2.691 in the lower-limit column.
5. Type 2.709 in the upper-limit column.

Do steps 1 through 5 again for calibration steps 2 through 4 with the values in Table 2.

Table 2. DC Voltage Test

Step	DC Input Voltage	Display Reading
1	+2.7 V	2.691 to 2.709 V dc
2	+27 V	26.91 to 27.09 V dc
3	+270 V	269.1 to 270.9 V dc
4	+1000 V	995 to 1005 V dc
5 ^[1]	+300 mV	299 to 301 mV dc
[1] 300 mV function only		

The calibration technician must move the Fluke 77 function switch to the millivolt position for the fifth calibration step. To have the Calibration Software show a message in the display, set a message step in the subsequent open row. Add a 5080 V-Ω-A step to enter the values for the fifth calibration step from Table 2. Figure 11 shows the complete procedure.

	Description	Test Type	Test Mode	Test Value Expected Value	Lower Limit	Upper Limit
1						
2		Comment	This procedure is from Rev 1 of the Fluke model 77 service manual dated 11/99			
3		Message	Set the UUT function switch to VDC, and connect the Calibrator output to the Volt-Ohm terminals and COM input terminals of the model 77			
4		Show Document	5080_77.bmp			
5						
6		Message	Select the DC Volts range Connect a cable from the 5080A Normal Terminals to the UUT			
7	DC Volts	5080A V-Ω-A	DC Volts	2.70	2.691	2.709
8		5080A V-Ω-A	DC Volts	27	26.91	27.09
9		5080A V-Ω-A	DC Volts	270	269.1	270.9
10		5080A V-Ω-A	DC Volts	1000	995	1005
11						
12		Message	Switch the model 77 to the mV function			
13		5080A V-Ω-A	DC Volts	300 m	299	301
▶ 14						

Figure 11. Completed DC Voltage Test for Fluke 77

How to Save a Procedure

To save a procedure:

1. Click  or click **File** and then point to **Save** from the main menu to open the **Save Procedure** dialog. See Figure 12.

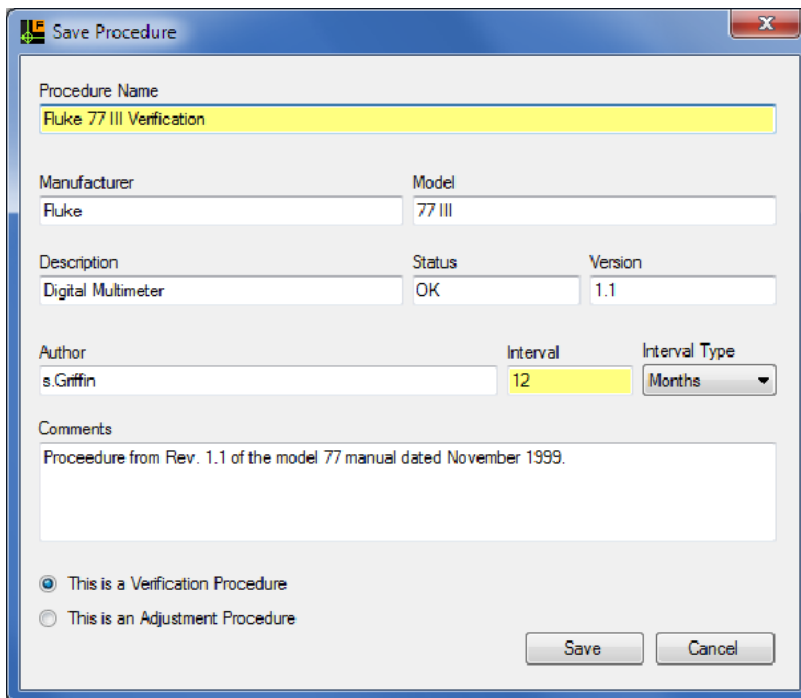

Procedure Name		
Fluke 77 III Verification		
Manufacturer	Model	
Fluke	77 III	
Description	Status	Version
Digital Multimeter	OK	1.1
Author	Interval	Interval Type
s.Griffin	12	Months
Comments		
Procedure from Rev. 1.1 of the model 77 manual dated November 1999.		
<input checked="" type="radio"/> This is a Verification Procedure		
<input type="radio"/> This is an Adjustment Procedure		
		Save Cancel

Figure 12. Procedure Save Dialog

gji16.bmp

2. Fill in the fields of the form with data about the product. Fields in yellow must have data.
3. Click the **Save** button.

This completes the procedure for the dc volts tests of the Fluke 77 Multimeter.

The ac voltage tests for the multimeter are added to the Calibration Software the same as the dc tests. As shown in Figure 13, there are auxiliary settings that are also necessary. Each 5080A Test Type and test mode has their own auxiliary settings. The auxiliary values are set to the default values as each test is added to the Calibration Software. If necessary, change these settings for the test and the product to test.

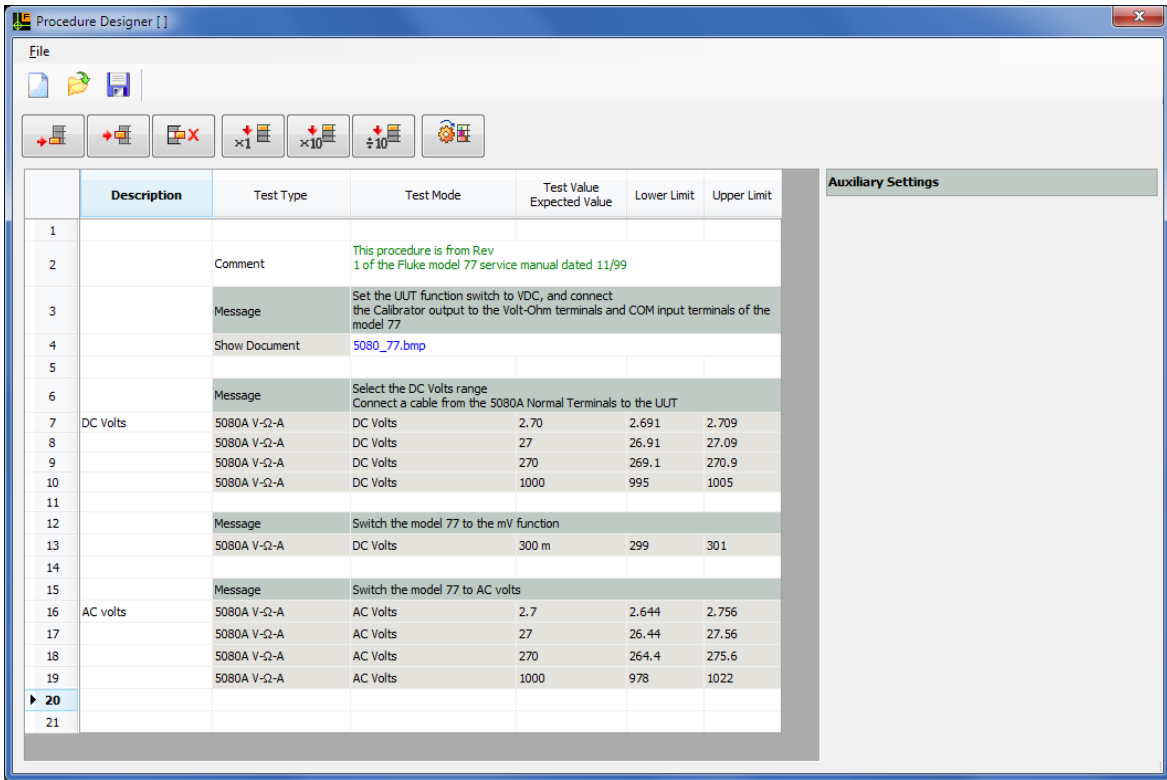

Figure 13. Fluke 77 Test Procedures with Auxiliary Settings

gji17.bmp

For ac voltage tests, Table 3 shows the frequencies used for the different test steps. Set the frequency in the Auxiliary Settings part of the display.

Table 3. AC Voltage Test

Step	Input		Display Reading
	Voltage	Frequency	
1	2.7 V	100 Hz	2.644 to 2.756 V ac
2	2.7 V	500 Hz	2.644 to 2.756 V ac
3	1000 V	100 Hz	978 to 1022 V ac
4	1000 V	1000 Hz	978 to 1022 V ac

Ohms Tests

The 5080A has fixed resistance values from 0 Ω to 190 MΩ. The values are in steps of 1.0 and 1.9. To make a 5080/CAL test for these values:

1. Click in the Test type column and click on 5080 V-Ω-A.
2. Click on Fixed Ohms from the Test Mode column.
3. Click the Test Value column and then the button in this cell. Click the down arrow in the 5080 Resistor list box and select a value.
4. Select a display format of ohms, k-ohms, or M-ohms to match the readout of the item being calibrated.
5. Type in the test limits. See the “Voltage Tests” section of this manual.

Use the fixed resistance values of the calibrator for the first seven steps of the resistance tests. See Table 4.

Table 4. Resistance Test

Step	Input Resistance	Display Reading
1	short	0.0 to 0.3 Ω
Decades of 1:		
2	100 Ω	99.2 to 100.8 Ω (plus 0 reading)
3	1 k Ω	994 to 1006 Ω
4	10 k Ω	9.94 to 10.06 k Ω
5	100 k Ω	99.4 to 100.6 k Ω
6	1 M Ω	0.994 to 1.006 M Ω
7	10 M Ω	9.79 to 10.21 M Ω
Other resistance tests use resistance values in decades of 2.7.		
Decades of 2.7:		
2	270 Ω	268.3 to 271.7 Ω (plus 0 reading)
3	2.7 k Ω	2685 to 2715 Ω
4	27 k Ω	26.85 to 27.15 k Ω
5	270 k Ω	268.5 to 271.5 k Ω
6	2.7 M Ω	2.685 to 2.715 M Ω
7	27 M Ω	26.45 to 27.55 M Ω

Resistance tests are done with the fixed resistance values available from the calibrator or an external resistor or decade box. If you use the fixed resistance values, such as 190 Ω for the 270 Ω test, then calculate the new lower and upper limits for this value. If you use an external resistance, use the manual test feature of the Calibration Software.

Compensating for Test Lead Resistance

To do a test of an item at low resistance values, the test lead resistance may be significant in relation to the test limits. Fluke recommends that a test be used where the 5080A resistance value is 0 ohms and the reading is stored as an offset. Subsequent resistance tests up to 10 k Ω should have the **Apply offset** to reading box checked.

Manual Tests

Use the manual test feature of the Calibration Software when the 5080A does not offer a signal that is necessary for the test.

Manual Numeric Tests

When you do a test that results in a numeric value, use the manual numeric test. To type in a manual numeric test:

1. Click on the Test Type column and click on **Manual Test** in the dropdown list.
2. Click on the Test Mode column and click on **Numeric** in the dropdown list.
3. Type in the expected UUT reading.

4. Type in the test limits. See *Voltage Tests* for more information on how to type in test limits.
5. In the Auxiliary Settings property grid, enter the measurement units and run-time operator prompt.

Most manual tests include an operator message with instructions on how to do the test and a list of equipment. When the procedure is executed, the operator follows the directions and then enters the test value. The software compares the UUT reading with the lower limit and upper limit and then shows the results.

Manual Text Tests

When the test results are not a numeric value, use the Manual Text test feature. The Manual Text test has two test mode settings: Yes=Pass and N = Pass. The two examples that follow show the difference in these two modes.

One example of a Manual Text test is a beeper test on a multimeter. For this test, the Test Mode is set to “Text (Y=Pass)”. When you do the beeper test, a prompt tells you to set the multimeter to the beeper function and to short the test leads together. The Calibration Software shows the question:

Did the beeper sound?

If the answer is Yes, the test passed. A No response results in a failed test.

A different example is a display segment test of a multimeter. For this test, the Test Mode is set to “Text (N=Pass)”. When you do the procedure, the Calibration Software shows the question:

Are any of the display segments missing?

If the answer is No, the test passed. A Yes response results in a failed test.

Figure 14 shows the test procedure with the voltage tests, manual ohms test, and the two manual text tests.

	Description	Test Type	Test Mode	Test Value Expected Value	Lower Limit	Upper Limit
4		Show Document	5080_77.bmp			
5						
6		Message	Select the DC Volts range Connect a cable from the 5080A Normal Terminals to the UUT			
7	DC Volts	5080A V-Ω-A	DC Volts	2.70	2.691	2.709
8		5080A V-Ω-A	DC Volts	27	26.91	27.09
9		5080A V-Ω-A	DC Volts	270	269.1	270.9
10		5080A V-Ω-A	DC Volts	1000	995	1005
11						
12		Message	Switch the model 77 to the mV function			
13		5080A V-Ω-A	DC Volts	300 m	299	301
14						
15		Message	Switch the model 77 to AC volts			
16	AC volts	5080A V-Ω-A	AC Volts	2.7	2.644	2.756
17		5080A V-Ω-A	AC Volts	27	26.44	27.56
18		5080A V-Ω-A	AC Volts	270	264.4	275.6
19		5080A V-Ω-A	AC Volts	1000	978	1022
20						
21		Message	Select the Ohms mode and connect an external 270 Ohm resistor.			
22	Manual Ohms Test	Manual Test	Numeric	270	268	271
23						
24		Message	Select the beeper function and short the test leadsw together.			
25	Beeper	Manual Test	Text (Y = Pass)	Did the beeper sound?		
26						
27		Message	Turn the unut off, then it back on again.			
28	Display	Manual Test	Text (N = Pass)	Were and display segments missing?		

gji21.bmp

Figure 14. Fluke 77 Test Procedure

Procedure Rules

Below are rules to keep in mind when you write a test procedure in the Calibration Software.

- Use of the description column is optional. Use it to describe the test or test function. The description can be used in a calibration report to describe the test being performed.
- For clarity, rows can be left empty.
- When you choose a Test Type and Test Mode, the auxiliary settings are initialized to default values. Set them as necessary.
- Each Test Type has its own background color.
- When you do a current test at less than 3 amps, the current is sourced from the Aux HI terminals. Currents more than 3 amps are sourced from the AUX 20A terminals.
- Ac volts and ac amps cannot be set to zero. Use a short on the Meter inputs for zero volts or amps.

Other Procedure Design Tools

More tools are available in the Calibration Software to help you make a calibration procedure.

Test Limits

Test limits can be typed in manually. You can also click on a percentage from the dropdown list, or select the limit calculator, see Figure 15.

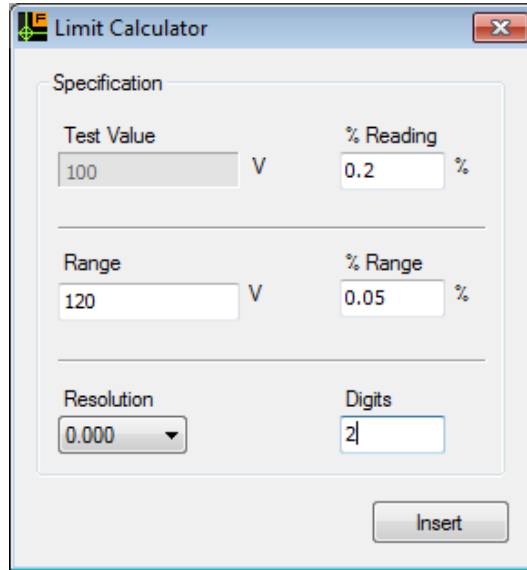

Figure 15. Limit Calculator

gji22.bmp

Note

When a lower limit is calculated from a percentage or with the limit calculator, the upper limit is calculated as well. If the upper limit is selected from a percentage or calculated, then only the upper limit is added. This lets you type in non-symmetrical values.

AutoPro Wizard

Use the AutoPro Wizard when a range of test values are necessary for a test procedure. To make test steps with the AutoPro Wizard:

1. Click  to open the AutoPro Wizard form in Figure 16.

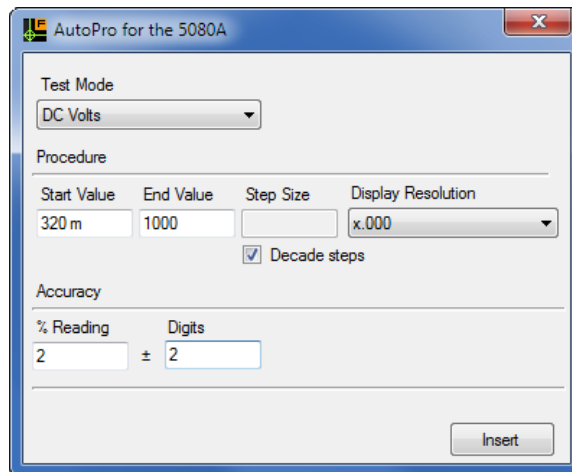



Figure 16. AutoPro Wizard Form

gji24.bmp

2. Click  in the test mode field to open the dropdown list.

3. Type in a start and end value.
4. When you make tests for devices such as a multimeter, set the **Decade steps** checkbox. In the example in Figure 16, the test steps are 320m, 3.2, 32, 320, and 1000 volts.
5. Type in the display resolution and accuracy specifications.
6. Click the Insert button.

Figure 17 shows the test steps made by the AutoPro Wizard for the ac volts tests.

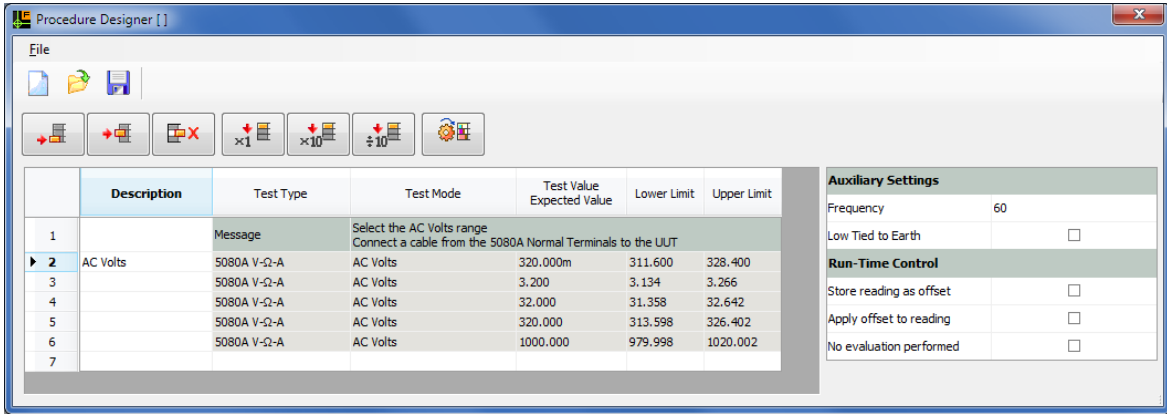

Figure 17. AutoPro Wizard Created Test Steps

Analog meters use incremental tests with procedure tests at primary points along the scale. For these meters, do not set the Decade steps checkbox. As an alternative, type in a test step value. The values in Figure 18 were used to make the test steps in Figure 19.

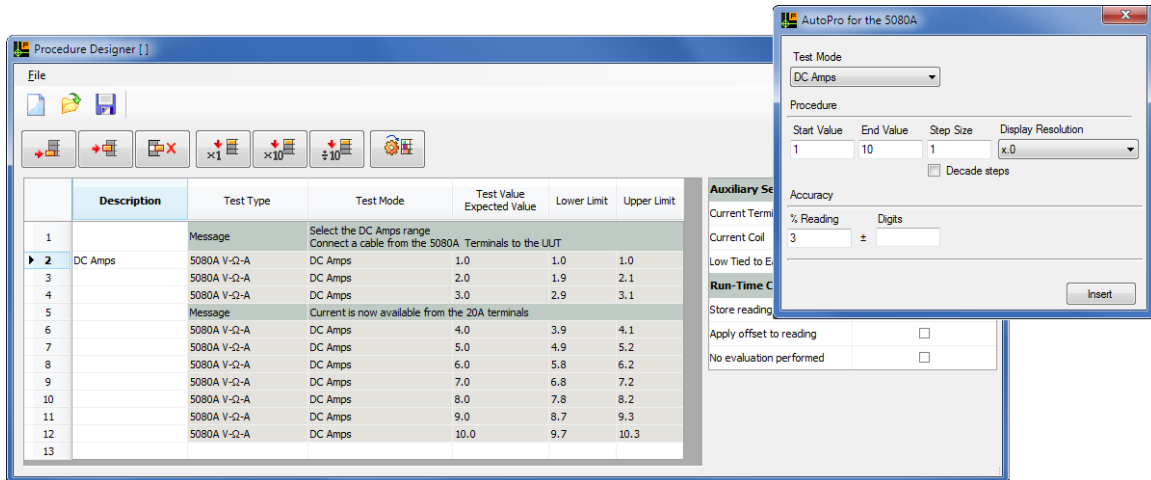

Figure 18. AutoPro Wizard Settings with Step Size Set

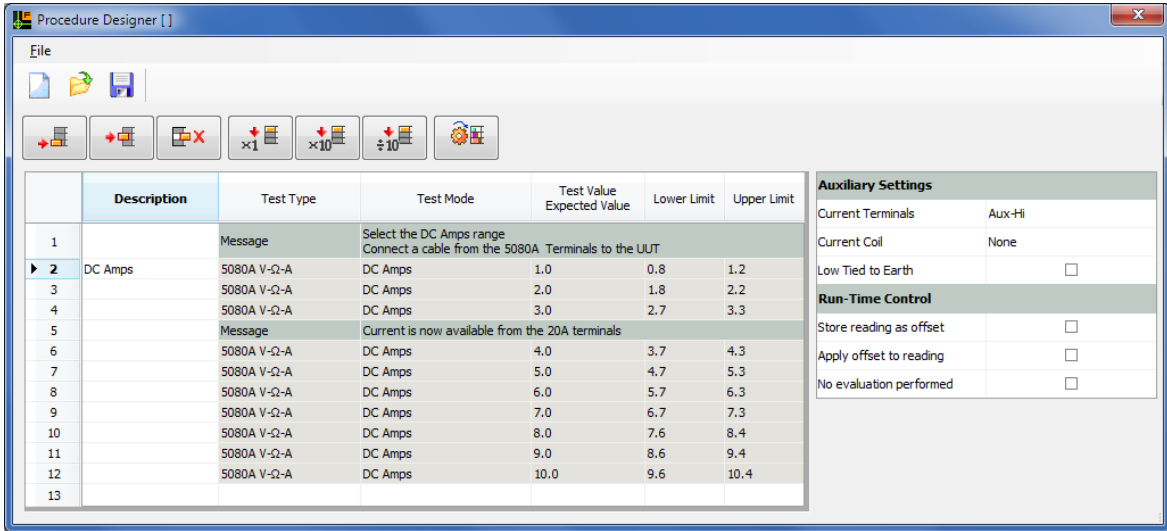



Figure 19. Test Steps Created with Setting Step Size

Performing a Calibration

After one or more procedures are done, they are set to use on a calibration item. To start a calibration:

1. Click  or point to **Calibrate with the 5080A** from the **Tools** menu or press **F2**.
2. Type in the asset number of the item to be calibrated, or click  to find the item.
3. Highlight a calibration procedure from the list in the **Procedure to be used** screen as shown in Figure 20 and click **OK**.

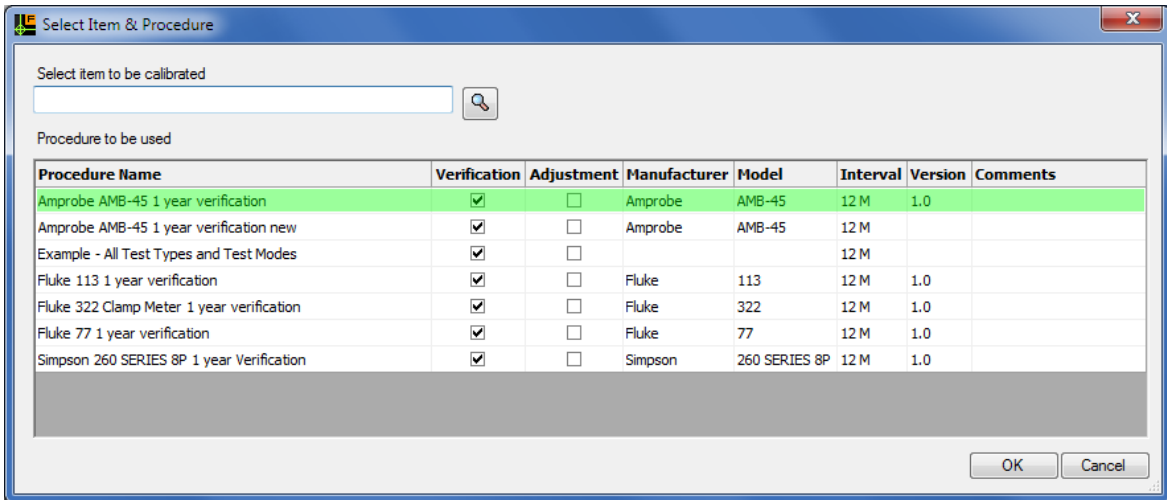
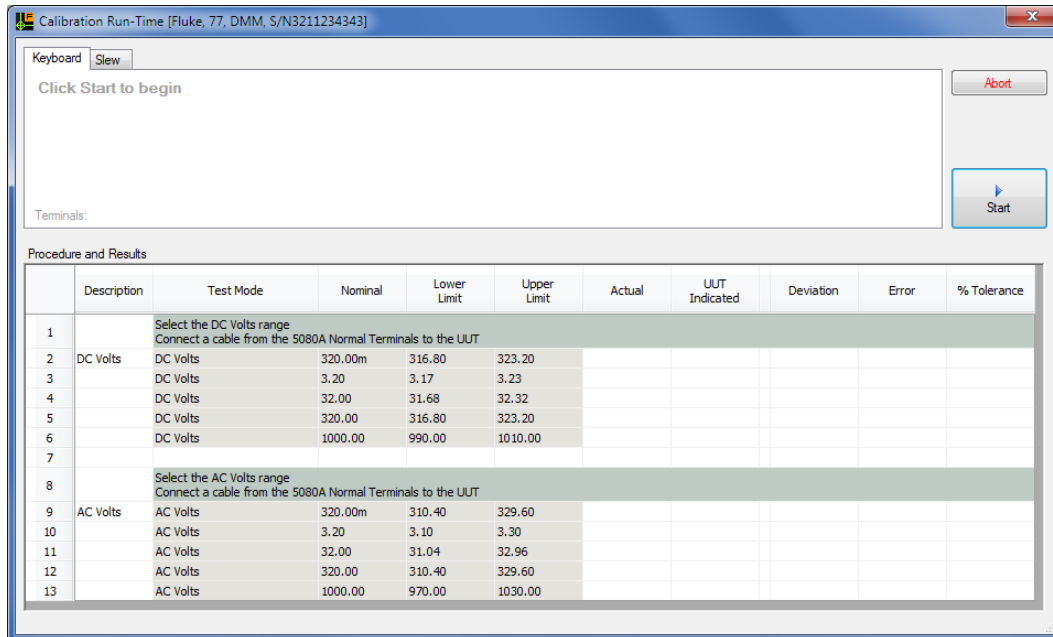

Figure 20. Select Item and Procedure Screen

After the UUT and calibration procedure are highlighted, the calibration screen in Figure 21 shows in the display.



gji29.bmp

Figure 21. Calibration Screen

1. Click the start button to begin the calibration.

From row one, each step of the procedure is read by the Calibration Software. Each message row shows instructions or setup and connection information. The other test steps send commands to the 5080A to source a test signal.

2. With the signal applied to the UUT, the technician types in the UUT measurement. This is done through the keyboard or the slew feature.

Click on the Keyboard or Slew tab near the top of the screen to set the type of data entry. When slewing, use the computer arrow keys to increase or decrease the signal from the 5080A until the UUT shows the test value. With the UUT measurement recorded into the Calibration Software, push Enter or click the OK button.

If a test passes, a green bar shows on the test line. If a test result is greater than a limit, the technician can do the test again or continue. A failed test shows in the display with a red mark. Each test shows a pass or fail color. The overall pass/fail indication is a red or green bar in the upper-right corner of the input panel. When all tests are done, the Post Calibration screen shows in the display, see Figure 24.

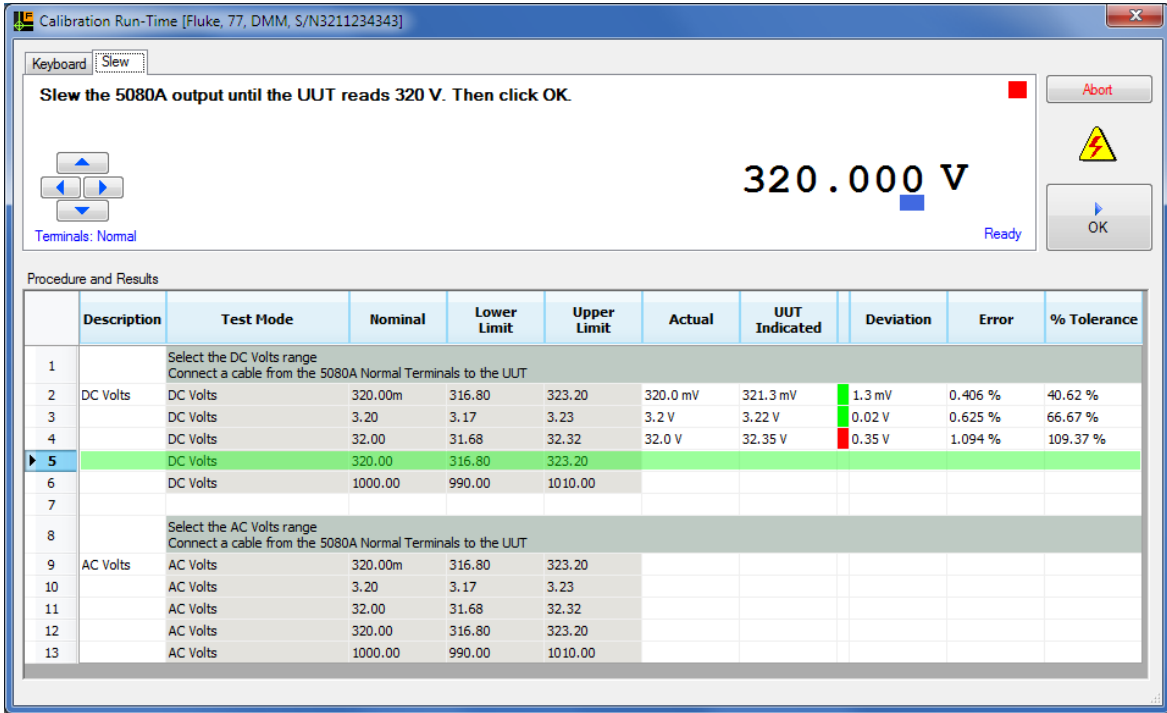

Figure 22. Calibration Screen with Test Results

gji30.bmp

Figure 23 shows the calibration screen resized to hide the calibrations details.

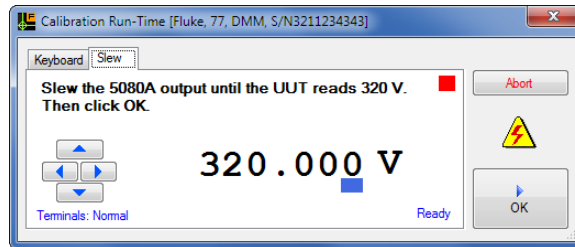

Figure 23. Resized Calibration Screen

gji89.bmp

Post-Calibration Screen

More data about the calibration is put into a post-calibration screen, see Figure 24.

The screenshot shows a software window titled "Save Calibration" with a blue title bar and standard Windows window controls. The window is divided into several sections:

- Calibration Information:** A form with fields for Due Date (04 Dec 2011), Certificate Number (092384), Calibration Technician (SEG), Temperature - °C (72.0), Humidity - %RH (35), and Calibration Regulation (QS - 403B).
- Calibration Notes:** A large empty text area for entering comments.
- Calibration Standards:** A table with a search icon and a delete icon (X). The table contains one row of data.

Asset Number	Manufacturer	Model	Description	Serial Number	Calibration Date	Due Date
Sample F	Fluke	5080A	Calibrator	1314018	04 Dec 2010	04 Apr 2012

- Item Calibrated:** A form with fields for Asset Number (Sample A), Manufacturer (Fluke), Model (77), and Serial Number (3211234343).

gji31.bmp

Figure 24. Post-Calibration Screen

Before you save the calibration record, add a certificate number if needed, the technician name, regulations, and environmental conditions. Add comments about the calibration. If you use calibration standards other than the 5080A, put that data into the Calibration Software through this screen. When the data is complete, click on the **Save** button.

After you add the calibration data to the database, the report screen shows in the display, see Figure 25.

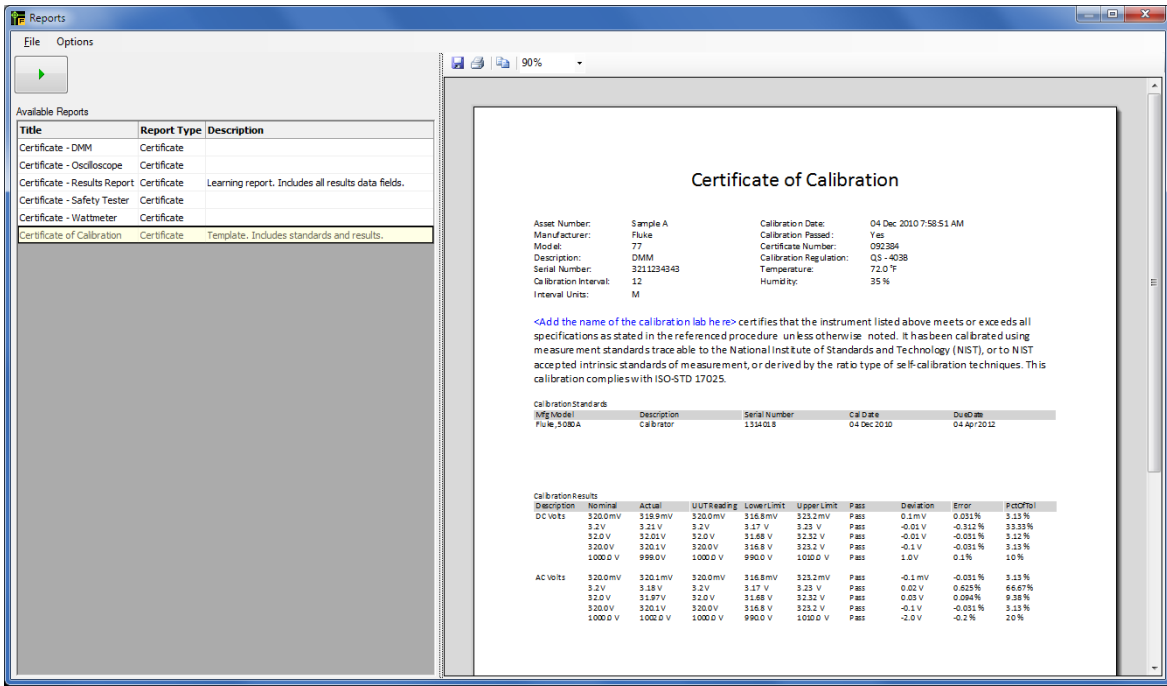

Figure 25. Report Screen

gji34.bmp

Highlight one of the calibration reports and click on the Run button. Reports can be printed or exported. Export file formats are Microsoft Word and Adobe Acrobat (PDF). The report can also be copied to the Windows clipboard and pasted into Microsoft Word to edit and format.

How to Run Reports



The Calibration Software includes a number of reports. Click on the reports button on the main screen, or click on Run Reports from the Tools menu. Or, push **F4**.

The Reports screen shows in the display, see Figure 26.

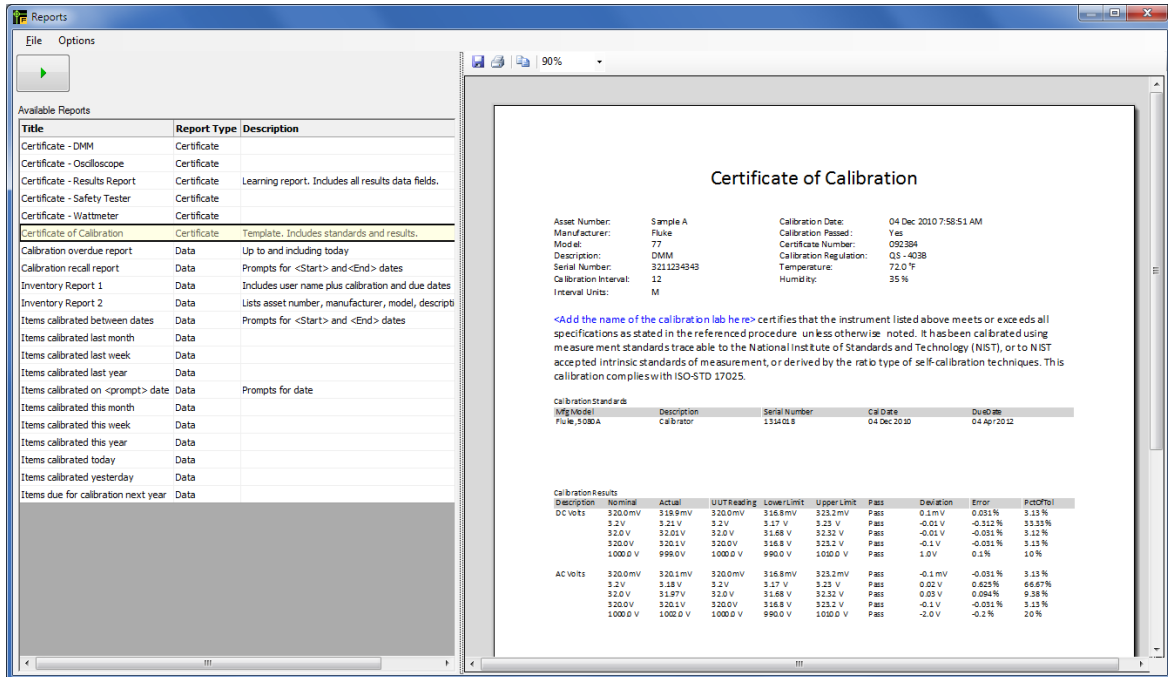
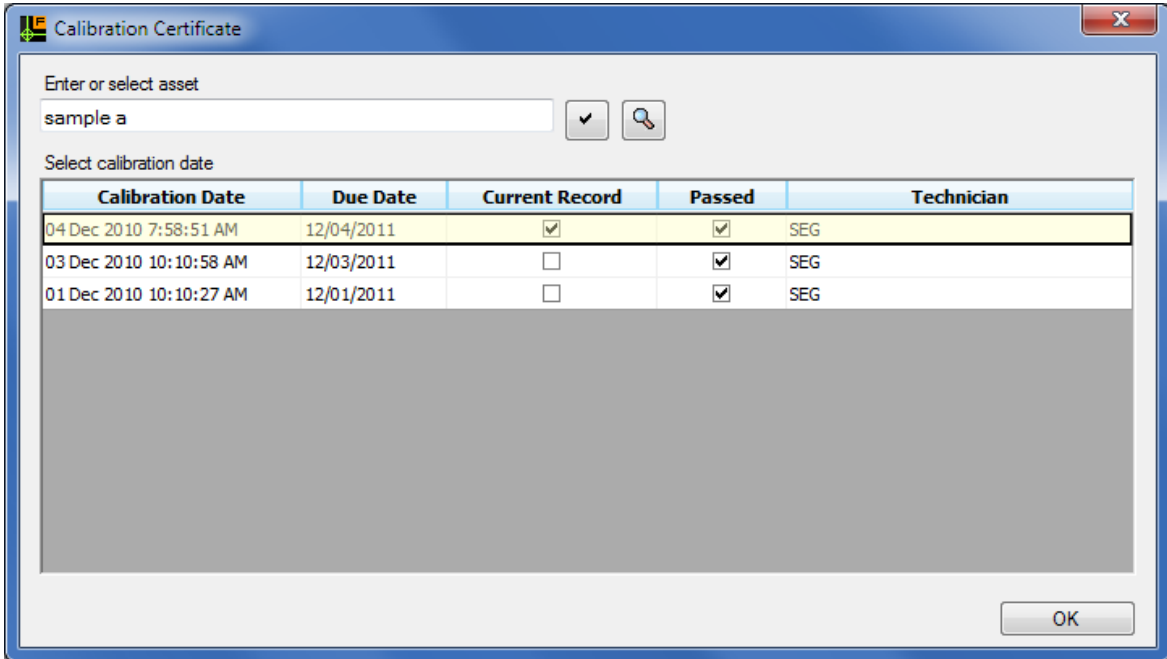

Figure 26. Reports Screen

There are two report types: Calibration Certificates and Data Reports. Calibration Certificates are reports about a specified calibration event. These reports can contain calibration results and a list of calibration standards used in the calibration.

To start a certificate report:

1. Highlight a Calibration Certificate report from the list in the **Reports** screen shown in Figure 26.
2. Push Enter or click to open the Calibration Certificate screen shown in Figure 27.
3. Type in or search for an asset number in the **Enter or select asset** field.
4. Push Enter when the correct asset number is shown in the asset number field.
5. Highlight the calibration date for the Calibration Certificate report.
6. Click **OK**.



gji35.bmp

Figure 27. Item and Calibration Date Selection Screen

Data Reports are for lists of database data. These reports can be inventory, calibration recall, or overdue reports.

How to Create Reports

The method used to create reports is similar to typing a report into a word processor. When you make a report in the report designer, you make a report template that will be used to make the actual report. When the report is started, database data is added to the template which makes a complete report.

Calibration Certificates

Click **Tools** and then point to **Certificate Designer** from the main menu or push **F10** to open the screen shown in Figure 28.

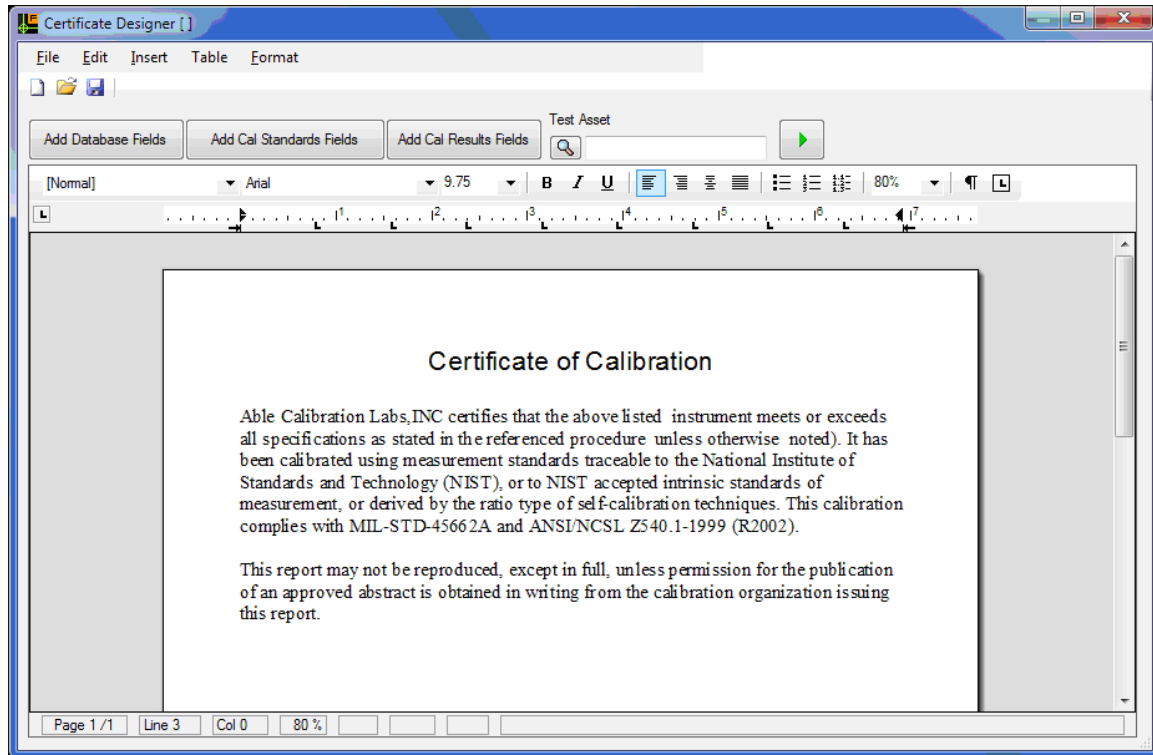

Figure 28. Certificate Designer Screen

A Certificate report is text that you type, such as the title and a quality statement. The report can include inventory data to identify the item calibrated, the calibration standards used, and calibration test results.

When the certificate designer opens, type in the title and text for the report. Font and font attributes are set through the toolbar. Figure 28 shows an example of the start of a certificate of calibration.

How to Add Database Fields to a Report

To add a database field:

1. Move the cursor to where a database field is to be added.
2. Click on the **Add Database Fields** tab.

3. Click on a field from the list box as shown in Figure 29 and push Enter.

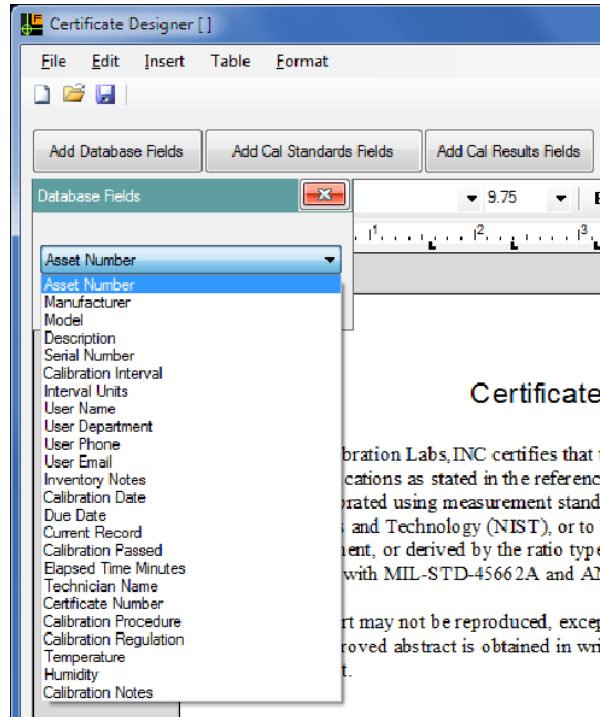

Figure 29. Adding a Database Field to a Report

gji37.bmp

The field is added to the word processor screen. Continue to add all the fields necessary to identify the item that was calibrated and calibration data. See Appendix C for a list of database fields.

Figure 30 shows an example report with some data fields.

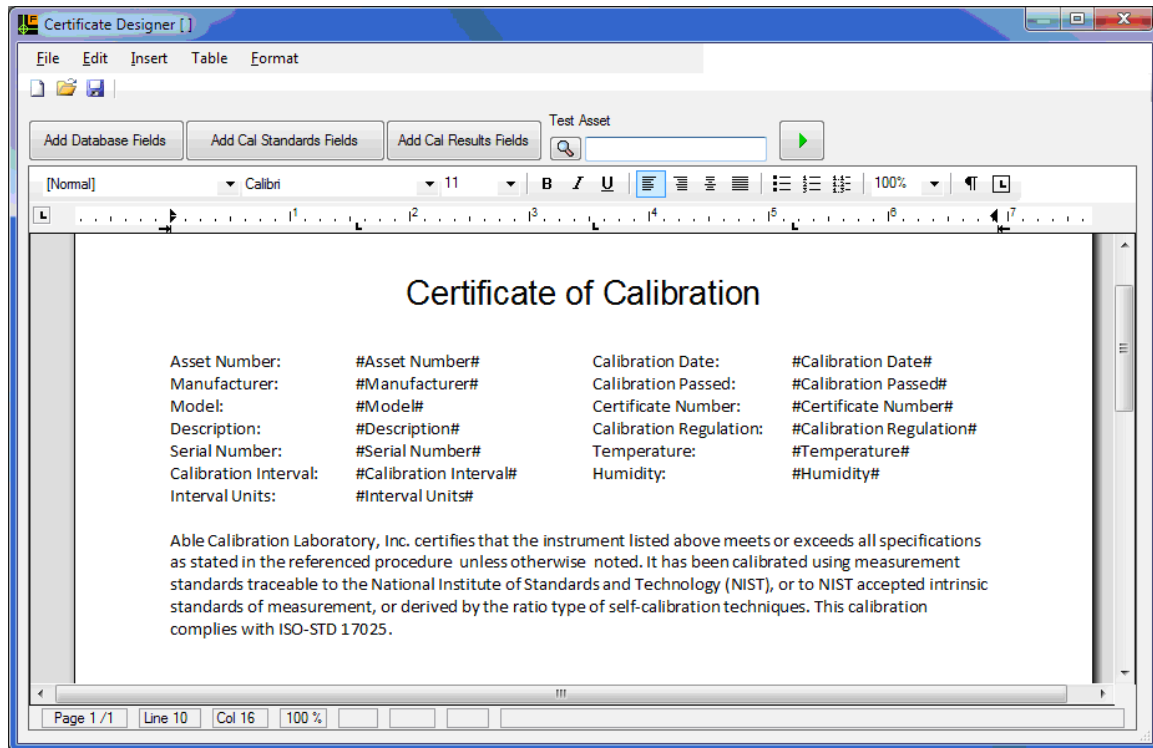



Figure 30. Completed Certificate of Calibration Design

gji38.bmp

The database fields on a template are shown with the name of the field between two "#" symbols. You cannot edit these fields. To remove a field, click on it and push the Delete key.

To start a report:

1. Click . The database fields will be replaced with data from the database.

In Figure 36, the data for asset number "1000" is used in the report. Calibration data is from the item's most recent calibration record. Fluke recommends that you make a sample asset with a calibration record that can be used to make a Certificate Report.

2. After previewing the report, click  to go back to the Design mode.

How to Add a List of Calibration Standards

To add a list of calibration standards to a report:

1. Move the cursor where a calibration standards field is to be added.
2. Click on the **Add Cal Standards Fields** button to open the screen in Figure 31.

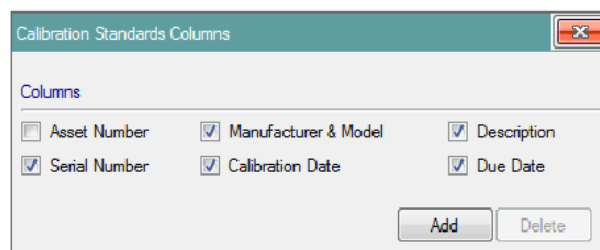

Figure 31. Calibration Standards Insertion Screen

gji40.bmp

3. Click on the checkbox of each data column to include in the Calibration Standards list.
4. Click **Add**. The Standards list can be changed or removed.

Figure 32 is an example of the standards list.

Calibration Standards

Mfg Model	Description	Serial Number	Cal Date	DueDate

gji41.bmp

Figure 32. Calibration Standards List

To set the font, font size, colors, and attributes, highlight the text first. To set the width of the columns, click on the vertical divider and pull it left or right.

How to Add Calibration Results

To add calibration results to the report:

1. Move the cursor to the location where the calibration results are to be added.
2. Click on the **Add Cal Results Fields** button to open the screen shown in Figure 33.

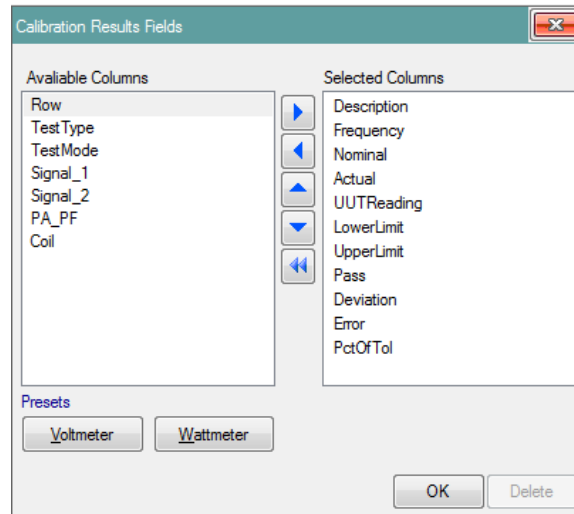

gji42.bmp

Figure 33. Calibration Results Field Selection

3. To add data from a results field to the report, click on a results data name in the Available Columns list and push Enter.

The calibration results are put in a table, see Figure 34.

Calibration Results

Description	Nominal	Actual	UUTReading	Lower Limit	Upper Limit	Pass	Deviation	Error	PctOfTol

gji43.bmp

Figure 34. Calibration Results Table

See Appendix D for a list of results table columns and how they are used by the Calibration Software.

When the report is started, the results from the calibration fill in the table. The report in Figure 35 is an example of a completed report template.

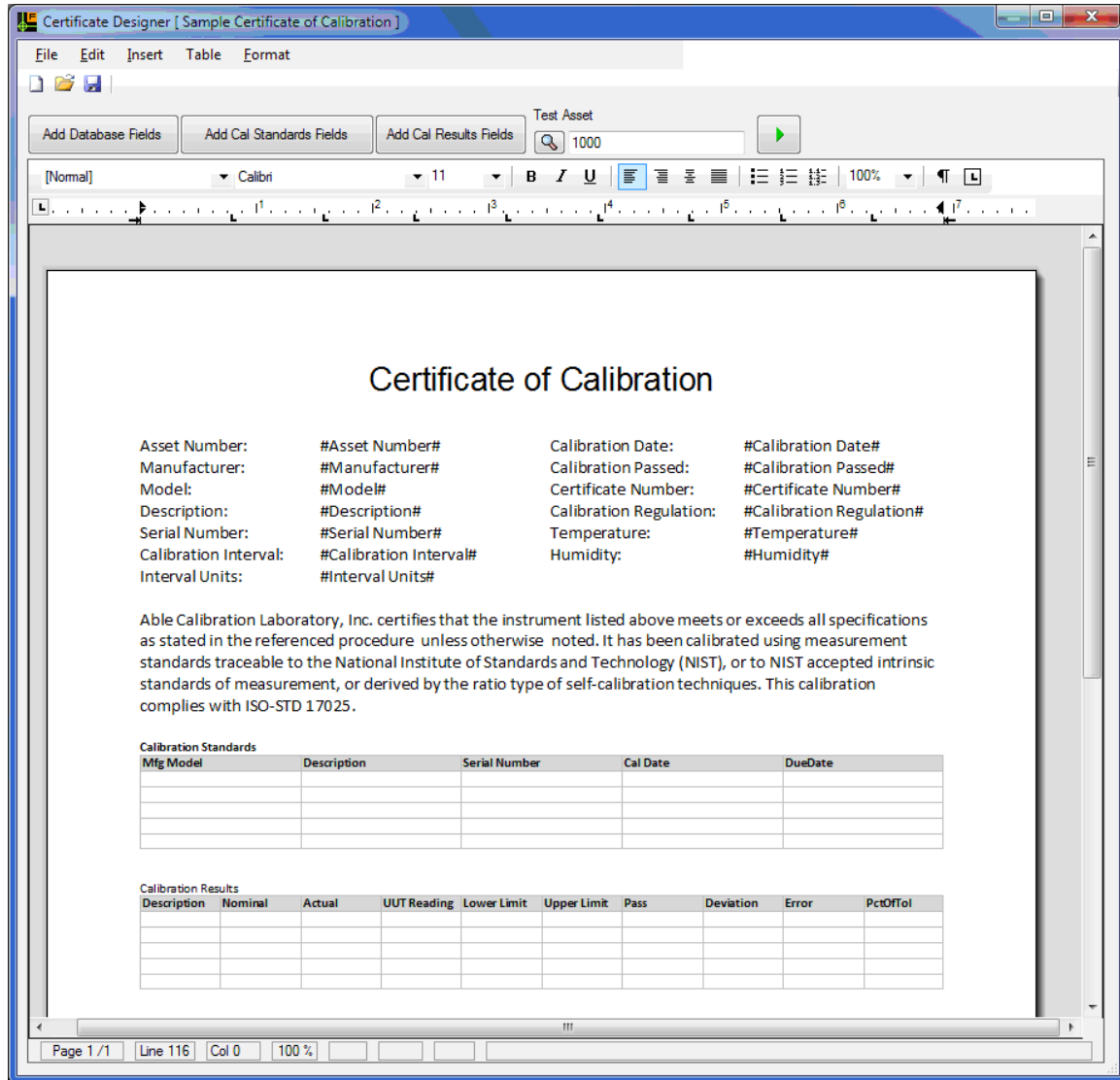

Figure 35. Certificate of Calibration Report Template

gji44.bmp

When you start this report, the tables and data fields are filled in with data from the database. The report in Figure 36 is an example of a completed report.

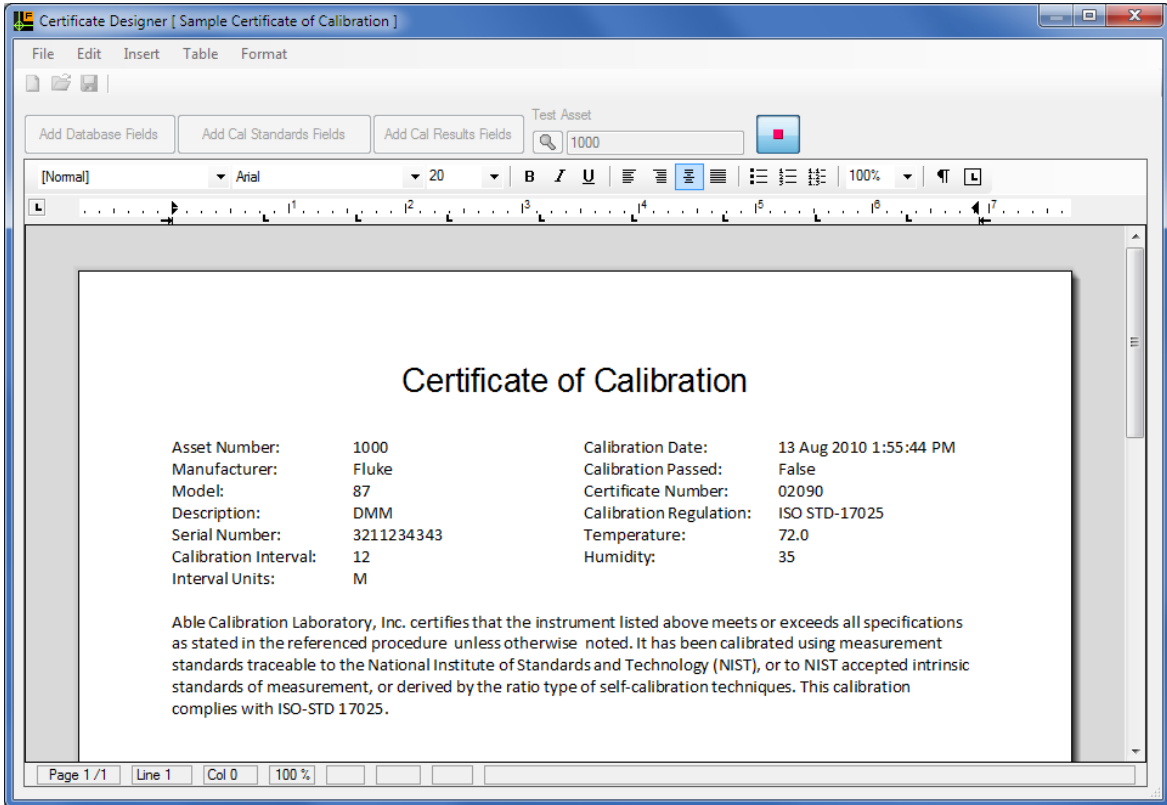



Figure 36. Completed Certificate Report

gji58.bmp

How to Save the Report

To save the report:

1. Click , or click **File** and then point to **Save** from the main menu, or push CTRL+S to open the dialog box shown in Figure 37.

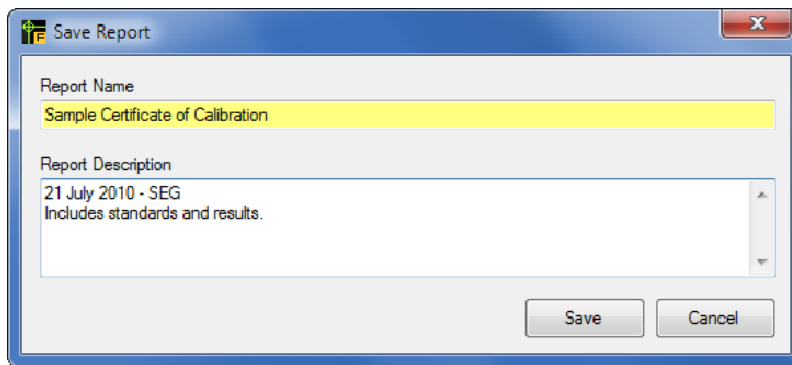

Figure 37. Save Report Screen

gji46.bmp

2. Type a report name in the report name field and a description if necessary. The report name must not be the same as other calibration report names.
3. Click **Save**.

Data Reports

Click **Tools** and then point to **Report Designer** from the main menu or push **F9**. When the Data report opens, type in the report title.

To add data to the report:

1. Move the cursor to the location in the table where results are to be added.
2. Click on the **Add Report details** button to open the form shown in Figure 38.

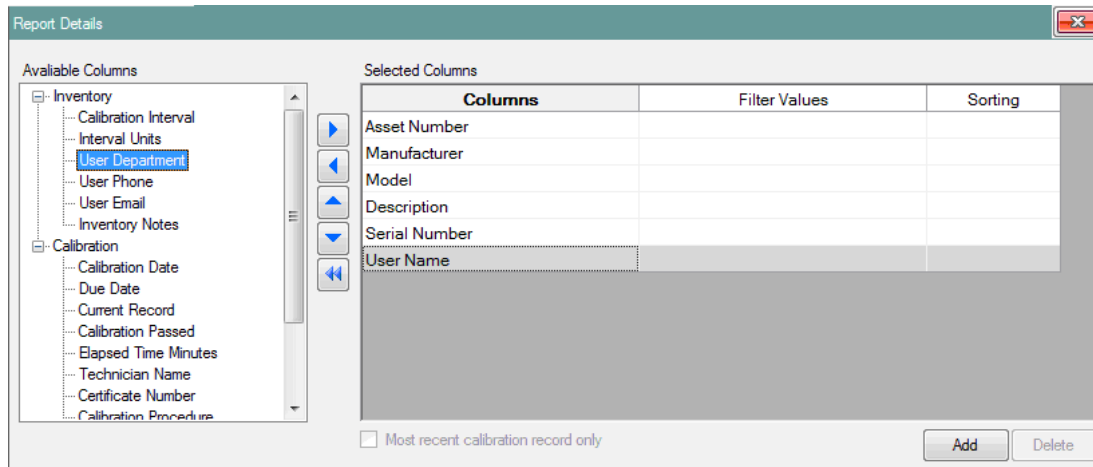

Figure 38. Report Details Selection

gji47.bmp

3. Click on a data field in the **Available Columns** list and push Enter or click on the blue right button. This moves the name to the **Selected Columns** list.

Do step 3 again for each field that is necessary for the report. Change the paper orientation from Portrait to Landscape if the column number is too great for portrait orientation.

Click **Add** when all fields are added. The report template in Figure 39 is an example data report template. After the table is created, you can set the column widths and font size to fit the data on to the report.

Inventory Report					
Report Details					
Asset Number	Manufacturer	Model	Description	Serial Number	User Name

Figure 39. Inventory Report Template

gji48.bmp

The Data Report template in this example prints all the data in the database. A possible report of 40 to 50 pages in length. A more usable report is one where the data is filtered to limit the number of rows in the report.

How to Filter a Report

To filter a report, add filter values in the Selected Columns screen of the report designer. Type filter values in to the Filter Values column in the report designer. You can also click on a value in the drop-down list that opens when you click on a button at the right side of the field.

The example in Figure 40 uses a filter to include all items with a manufacturer of Fluke or Keithley and have DMM as a description. This example also shows how to use multiple filter values.

How to Sort a Report

The report is sorted when you select a sort direction in the Sorting column of the report designer. Click in a Sorting column cell and type in a sort value. The example in Figure 40 makes a report that is sorted in ascending order by Model.

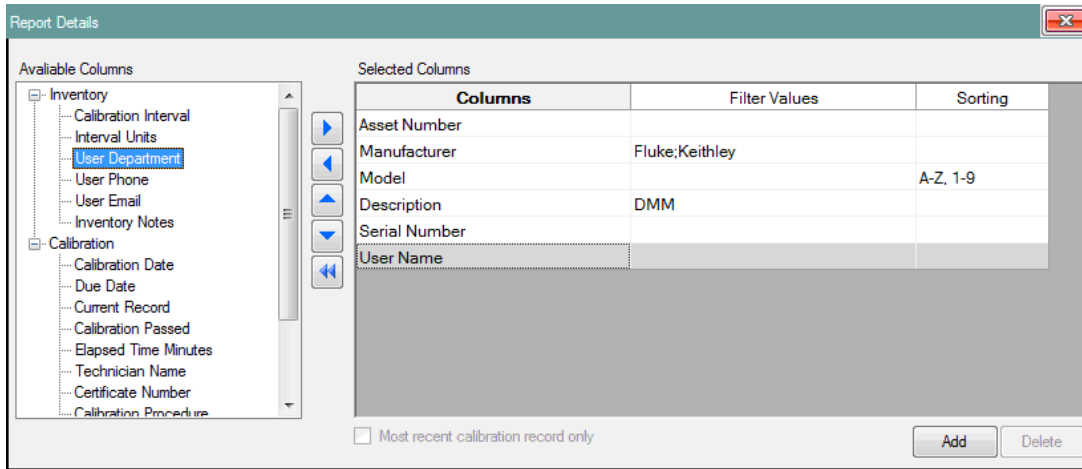

Figure 40. Report Details Screen

gji49.bmp

When a report is filtered on a date field, these filter selections are available:

- Select a date at run-time
- Select a date range at run-time
- Yesterday
- Today
- Up to today
- Tomorrow
- Last week
- This week
- Next week
- Last month
- This month
- Next month
- Last year
- This year
- Next year

You can use these selections to filter the Calibration Date and Due Date fields.

Click on **Most recent calibration record only** to have only the most recent calibration data in the report. This makes a calibration recall report. When you start the report, the dialog box in Figure 41 shows in the display. Use this dialog box to set the start and end dates of the report.

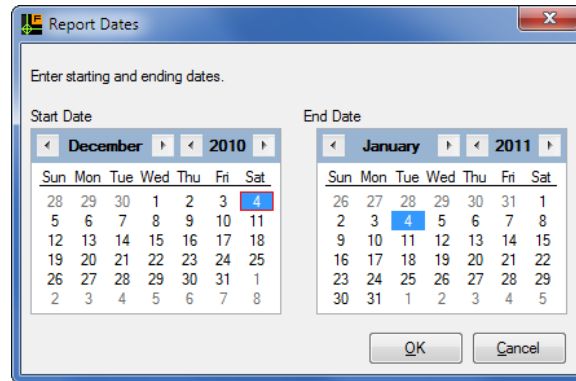

Figure 41. Start and End Date Dialog Box

gji51.bmp

If the Due Date filter value was <Next Month>, the report shows those items due for calibration in the next month.

If Calibration Date field was filtered with <Last Week>, all items calibrated in the previous week show in the report.

The report in Figure 42 is a recall report sorted by Due Date descending.

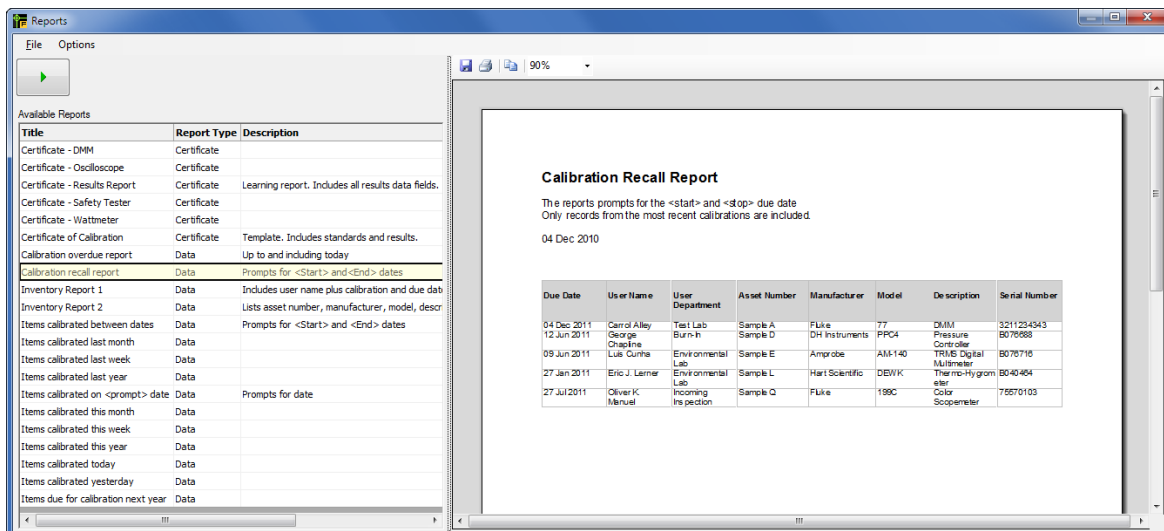

Figure 42. Recall Report Sorted by Due Date

gji52.bmp

Other Report Layout Tools

Other report layout tools are:

- Page headers and footers can be added through the Edit menu.
- Images can be added for company logos or a person's signature.
- A text frame can be added to contain special data.
- Tables can be added for more report data.
- A report Print date can be added with the Insert menu.

Data Export Tool

You can export database data for use in other systems. The Data Export screen in Figure 43 is similar to the Data Reports Fields screen.

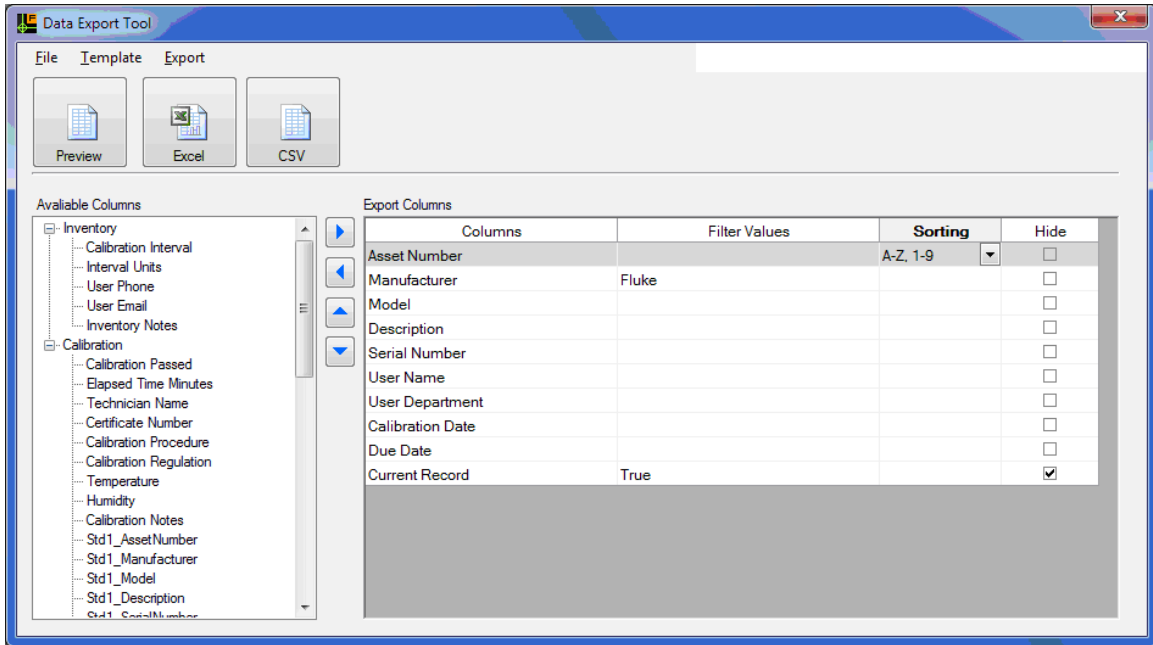

Figure 43. Data Export Screen

gjf53.bmp

Add the export fields with the blue buttons between the **Available Columns** and **Export Columns** parts of the screen. You can filter and sort the output. Use the checkbox in the hide column to filter and/or sort by a field but not include the data from that field in the export.

The example set up in Figure 43 will export the data on items with a manufacturer of Fluke and of those, only the current calibration record. This is done when the Current Record data field is added to the Export Columns list and its filter value is set to true. With the hide checkbox set, current record data is not exported.

The Calibration Software exports data in Excel or CSV file formats.

Procedure Import and Export Function

The Calibration Software can import procedures made by others or export procedures that others can use. The export function can also be of value if it becomes necessary to get help from the Fluke MET/SUPPORT group. One or more procedures can be contained in one export file.

How to Export Calibration Procedures

To export a procedure:

1. Click **Tools** on the main menu and then point to **Procedure Import/Export Tool**. The **Procedure Import/Export** screen in Figure 44 opens.

- Click on the checkboxes in the **Export** column adjacent to each procedure name to select the procedure.

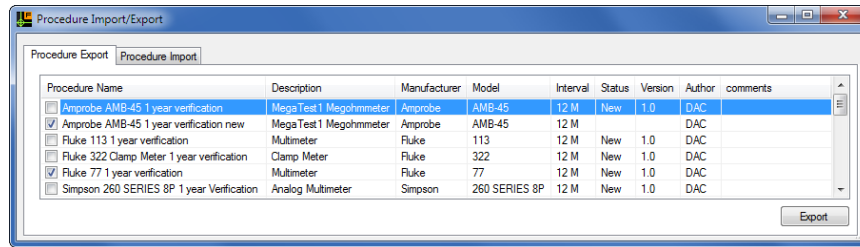

Figure 44. Procedure Export Screen

gji84.bmp

- Click on **Export**.
- A **Save File** dialog box opens. Navigate to the location where the procedure file is to be kept and type in the procedure file name.

All exported files have a .PROC extension.

To sort the list of procedures, click on the column name.

You can email the file to other 5080/CAL users or to the MET/SUPPORT group when necessary.

How to Import Calibration Procedures

To import a procedure:

- Click **Tools** on the main menu and then point to **Procedure Import/Export Tool**.
- Click **Open**.
- Navigate to the .PROC file to be imported, and click on the **Open** button.

Figure 45 shows a list of the procedures contained in the procedure file.

- In the **Procedure Import/Export** screen, click on the checkboxes in the **Import** column for each procedure to import from the file.

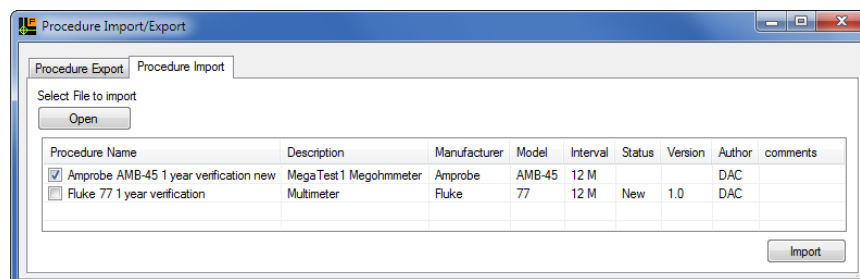

Figure 45. Import Procedure Screen

gji83.bmp

- Click **Import** to import the procedure(s).

You can not import a procedure that has the same name as a procedure that is already in memory. You can change the name of the imported procedure, change the name of the procedure in memory, or remove the procedure in memory. To overwrite a procedure in memory, you must open the Procedure Designer and remove or rename the procedure in memory.

Database Backup

The Calibration Software database is the heart of the system. Fluke recommends that you do frequent data backups. This backup procedure is available through the tools menu. The database file used by the system is named 5080CalRecords.sdf. When a backup file is made by this procedure, that backup file is named 5080CalRecords<TimeStamp>.bak. The timestamp part of the name is the date and time of the backup.

An example of a backup file name is:

5080CalRecords_22_Jul_2010_1_00_59_PM.bak.

The timestamp in yellow highlight shows this backup file was made on July 22, 2010 at 1:00:59 PM. Backup files are put in the same directory as the 5080/CAL programs.

Restore from a Backup

If the database becomes corrupt, change from the corrupted database to a backup database. To restore a database:

1. Click **Tools** and then point to **Restore from a backup** in the main menu.
2. Click on the backup file to be used.
3. Click **Open**.

The corrupted database is renamed to:

5080CalRecords_22_Jul_2010_1_00_59_PM.sdf.old.

The backup file is renamed 5080CalRecords.sdf. The time of the restore becomes a part of the name of the corrupted database file.

Options

To set options, click on **Tools** and then point to **Options** in the main menu. Through the options menu, you can:

- Set a Celsius or Fahrenheit temperature scale.
- Set the Error computation method for the Run-time slew mode:
 - Nominal Method
 - Relative error = Nominal/Output
 - Example: Output 1V, slew to 1.1V.
 - Relative error = -10.0%
 - True Value Method
 - Relative error = (Reference - Output)/Output
 - Example: Output 1V, slew to 1.1V.
 - Relative error = -9.09%
- Toggle the toolbar on and off

Communication with the 5080A Calibrator

To make a connection with the 5080A, use an RS-232 Serial cable or a USB Virtual Port cable. Fluke recommends that the Fluke 884x USB-to-serial-RS-232 interface adapter cable. This cable is 1.65 meters in length and changes from a standard DB 9-pin serial to a USB 2.0 connection. This option includes a USB driver disk (CD-ROM).

How to Install the USB to Serial driver

The USB serial driver should only be required on a PC with the XP operating system.

XP operating system – When the cable is plugged-in, XP shows a New Hardware Found message. Select Install from Disk and navigate to the CD to install the driver.

Vista and Windows-7 – No driver is necessary. The device is automatically configured when the USB-to-serial cable is plugged in.

How to Configure the 5080A to Communicate with the 5080/CAL Software

To configure the 5080A for communications with 5080/CAL software:

Click **Tools** and then point to **I/O Port Setup** from the main menu to open the dialog box shown in Figure 46.

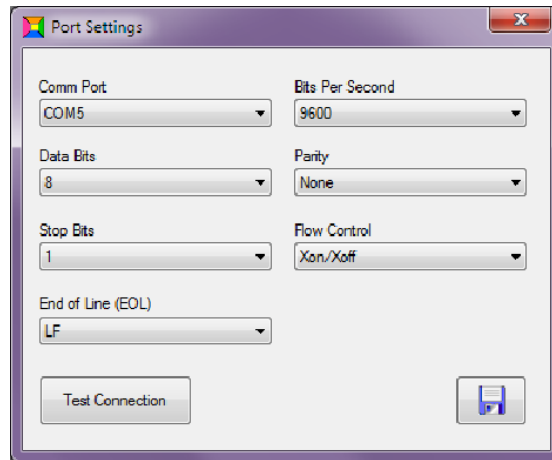



Figure 46. Port Configuration Dialog Box

gj55.bmp

By default, the 5080A is set to 9600 Baud, 8 Data bits, 1 Stop Bit, Xon-Off, EOF = LF. Follow the instructions in the 5080A Operators Manual to configure the instruments remote setup.

Be sure that the communication parameters in the 5080A agree with those in the Port Settings dialog box. Click on the Test Connection button to do a communication test with the 5080A. If a connection is not made, change the Com Port, and test again.

When the test shows a good connection, click .

If the 5080/CAL port settings are not the same as those of the 5080A, the connection test can cause the 5080A to show an Error. Push a 5080A blue softkey to clear the error from the 5080A. It could be necessary to push the softkey many times to clear all the errors.

Appendix A

Oscilloscope Calibration

Introduction

When the Scope Calibration option (5080A/SC) is installed in the 5080A you can calibrate analog and digital oscilloscopes with 200 MHz bandwidth or less. This section of this manual contains data on how the Calibration Software works with this option

Table A-1 lists the four modes of operation for an oscilloscope calibration.

Table A-1. Oscilloscope Calibration Modes of Operation

Mode	Description
Volt	Sources DC and AC voltages to measure the vertical gain of an oscilloscope
Fast Edge	Examines the rise time of an oscilloscope. The fast edge is specified to be less than 1 ns
Leveled Sine	Measures the bandwidth of an oscilloscope to a maximum of 200 MHz
Marker	Supplies a spike, square, or 20% duty cycle square wave to measure the horizontal time accuracy

How to Make Oscilloscope Procedures

The procedure designer is used to make calibration procedures. The screen has two parts. On the left is a spreadsheet grid that contains the procedure. The Auxiliary Settings supply more control of the 5080A.

Vertical Gain Accuracy

To make a procedure to examine the vertical gain accuracy of an oscilloscope start:

1. Click **Tools** and then point to **Procedure Designer** from the main menu or push **F8**.
2. Select the Test Type column and select 5080A Scope.
3. From the Test Mode column, select **Vertical**. Figure A-1 shows the completed procedure step.

Message	Set scope to 500mv/Div			
5080A Scope	Vertical	4	3.8	4.2

Figure A-1. Complete Vertical Gain Calibration Procedure

gji85.bmp

- Set the peak-to-peak amplitude, frequency, and impedance in the **Auxiliary Settings** section. Figure A-2 shows the default settings.

Auxiliary Settings	
Mode	AC volts
Amplitude - Vpp	2.0
Frequency	1000
Impedance	1 MΩ
Evaluation	Divisions
Run-Time Control	
Store reading as offset	<input type="checkbox"/>
Apply offset to reading	<input type="checkbox"/>
No evaluation performed	<input type="checkbox"/>

Figure A-2. Default Auxiliary Settings

gji86.bmp

- Use a Message Test type that contains instruction on how to setup the oscilloscope connected for calibration.

In this example, the 5080A sources a 2.0 Volts peak-to-peak square wave at 1000 Hz. With the oscilloscope set to 500 mv/div, the display looks equivalent to the one shown in Figure A-3. The procedure step shown in Figure A-1 shows a lower limit of 3.8 divisions and an upper limit of 4.2 divisions. The Calibration Software will pass this step if the amplitude of the square wave on the oscilloscope display is between these limits.

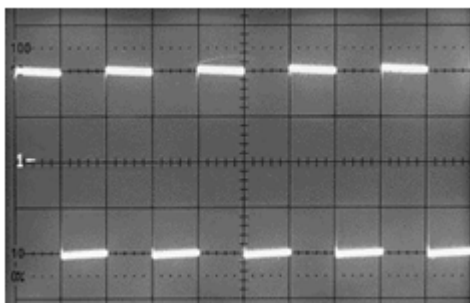

Figure A-3. Scope Display with 2 V p-p at 1000 HZ

gji71.bmp

Rise Time Calibration

The 5080A Fast edge is used to measure the rise time or pulse response of an oscilloscope. To see the rise time the 5080A Fast Edge is applied to the input of the oscilloscope. The sweep speed is increased to the fastest speed, and the sweep multiplier, if available, is turned on.

The rise time is the time for the trace to go from the 10 % to 90 % point. A digital scope can have a readout for rise time.

The Calibration Software can set the frequency and amplitude of the Fast Edge signal. The rise time is fixed and cannot be slewed. When you make a Rise time measurement, record the scope rise time seen in the oscilloscope.

Scope Rise Time and the Observed Rise Time

When a rise time measurement is made, the rise time of the Fast Edge signal must be considered. The formula to determine the scope observed rise time is:

$$t(\text{observed}) = \sqrt{(UUT \text{ rise time})^2 + (\text{Calibrator rise time})^2}$$

The Calibration Software has a built-in rise time calculator that shows in the display when a procedure row that has a test mode of Rise Time is highlighted. See Figure A-4.

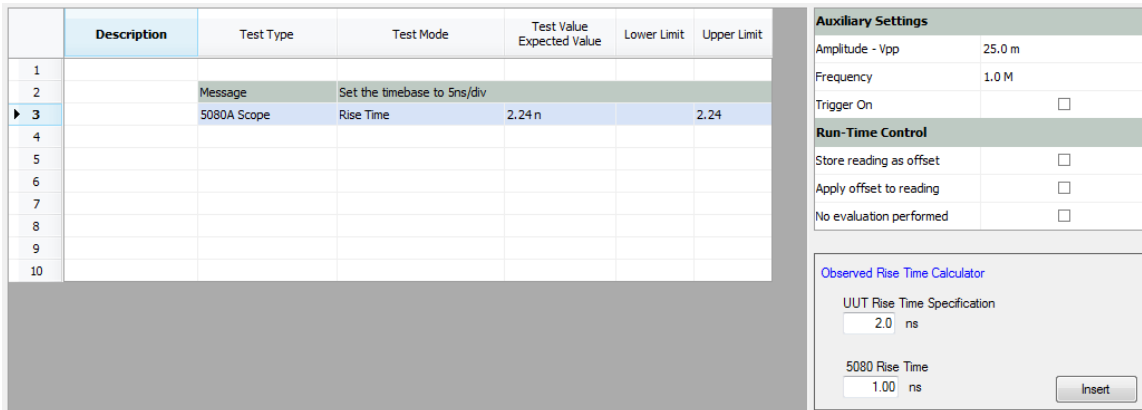

Figure A-4. Rise Time Calculator

gji65.bmp

To calculate the rise time that will be seen on the oscilloscope with the calculator:

1. Type in the scope rise time specification into the **UUT Rise Time Specification** field.
2. Type in the 5080A rise time specification into the **5080 Rise Time** field. Use 1 ns in this field unless the 5080A had a traceable calibration done on it. If it has, use the specification on the calibration certificate
3. Click **Insert**.

There are no limits for this test and it will pass if the rise time is equal to or less than the specification.

Actual Scope Rise Time

At run time, the technician types in the rise time seen in the oscilloscope. Use the formula below to calculate the actual scope rise time.

$$UUT \text{ actual risetime} = \sqrt{(UUT \text{ observed risetime})^2 - (\text{Calibrator rise time})^2}$$

As an example, the oscilloscope with the screen shown in Figure A-A-5 has a sweep speed of 5 ns/div.

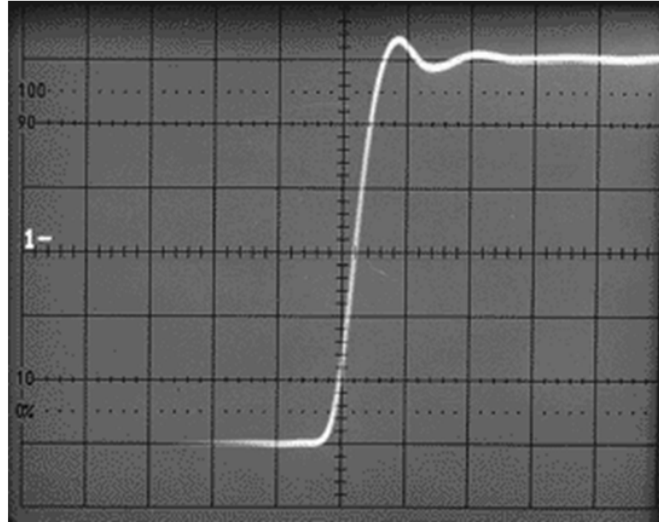

gji72.bmp

Figure A-5. Scope Display of Rise Time

The rise time seen in the display is approximately 2.5 ns. The actual rise time of the oscilloscope is calculated as:

$$\sqrt{2.5 \text{ ns}^2 - 1 \text{ ns}^2} = \sqrt{6.25 - 1} = \sqrt{5.25} = 2.29 \text{ ns}$$

When the user types in the rise time seen on the oscilloscope, the Calibration Software calculates and records the actual rise time of the UUT.

Bandwidth Testing

All oscilloscopes procedures test a scopes bandwidth. The test makes sure the oscilloscope can accurately show high-frequency signals. Usually, a 50 kHz reference signal is input to the oscilloscope and adjusted so the scope shows a deflection of 6 divisions.

The frequency is then increased to the scope bandwidth point without changing the input amplitude. On a Fluke 199C Oscilloscope, the bandwidth specification is 200 MHz. The bandwidth is correct if the observed 3 dB point amplitude is equal to or greater than 70 % of the value at the reference frequency. In this example, it will be 4.2 divisions (6 x 0.7).

Test step number 2 in the procedure shown in Figure A-6, sets the reference to 120 mV at 50 kHz. The function is set to *Set the reference amplitude* in the Auxiliary Settings. The operator prompt has given the instructions.

	Description	Test Type	Test Mode	Test Value Expected Value	Lower Limit	Upper Limit	Auxiliary Settings	
1							Amplitude - Vpp	120.0 m
2		Message	Set the scope to: 20 mv/div 10 μs/div Be sure to use a 50 ohm terminator.				Frequency	50.00 k
3		5080A Scope	Leveled Sine				Function	Set reference amplitude
4		5080A Scope	Leveled Sine				Operator Prompt	Slew 5080A to 6 divisions.
5							Run-Time Control	
6							Store reading as offset	<input type="checkbox"/>
7							Apply offset to reading	<input type="checkbox"/>
8							No evaluation performed	<input type="checkbox"/>
9								
10								

gji66.bmp

Figure A-6. Calibration Procedure for Bandwidth Test

At run time, the technician is instructed to slew the Leveled Sine amplitude until the scope displays 6 divisions of deflection

For test step number 4, the function is set to *Check bandwidth*, and the frequency is set to the UUT bandwidth frequency. In this example, it is 200 MHz. The amplitude is ignored as the 5080A keeps the same amplitude as that of the test before. See Figure A-7.

	Description	Test Type	Test Mode	Test Value Expected Value	Lower Limit	Upper Limit
1						
2		Message	Set the scope to: 20 mv/div 10 us/div Be sure to use a 50 ohm terminator.			
3		5080A Scope	Leveled Sine			
▶ 4		5080A Scope	Leveled Sine			
5						
6						
7						
8						
9						
10						

Auxiliary Settings	
Amplitude - Vpp	120.0 m
Frequency	200 M
Function	Check bandwidth
Operator Prompt	Is uut amplitude > 4.2 divisions?

Run-Time Control	
Store reading as offset	<input type="checkbox"/>
Apply offset to reading	<input type="checkbox"/>
No evaluation performed	<input type="checkbox"/>

gji67.bmp

Figure A-7. Bandwidth Test at 200 MHz

At run-time, the technician answers Y (yes) or N (no) to the question:

Is the amplitude ≥ 4.2 divisions?

The display shown in Figure A-8 shows a signal amplitude of 4.2 vertical divisions on the oscilloscope display.

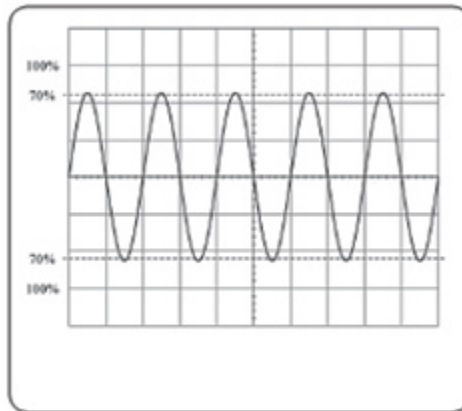

gji74.bmp

Figure A-8. Scope Display for Bandwidth Test

Bandwidth Measurements on Digital Oscilloscopes

Many digital oscilloscopes can show peak-to-peak voltage. When you calibrate this type of scope, the operator can use the display readout as an alternative to the analog display.

Test number 2 in the procedure shown in Figure A-9 will tell the operator to slew the 5080A until the UUT reads 100 mV. This is the reference level.

	Description	Test Type	Test Mode	Test Value Expected Value	Lower Limit	Upper Limit	Auxiliary Settings		
1							Amplitude - Vpp	100.0 m	
2		Message	Set the scope to: 20 mv/div 10 µs/div Be sure to use a 50 ohm terminator.					Frequency	50.00 k
▶ 3		5080A Scope	Leveled Sine				Function	Set reference amplitude	
4		5080A Scope	Leveled Sine				Operator Prompt	Slew the 5080A until the scope reads 100mv.	
5							Run-Time Control		
6							Store reading as offset	<input type="checkbox"/>	
7							Apply offset to reading	<input type="checkbox"/>	
8							No evaluation performed	<input type="checkbox"/>	
9									
10									

gji68.bmp

Figure A-9. Bandwidth Test on Digital Scope at 50 kHz

Test number 3 increases the frequency to 100 MHz. See Figure A-10. The operator has to type in Y (yes) or N (no) to the question:

Is the reading >70 mV?

If yes, the test passes because the bandwidth is larger than the specification.

	Description	Test Type	Test Mode	Test Value Expected Value	Lower Limit	Upper Limit	Auxiliary Settings		
1							Amplitude - Vpp	100.0 m	
2		Message	Set the scope to: 20 mv/div 10 µs/div Be sure to use a 50 ohm terminator.					Frequency	200 M
3		5080A Scope	Leveled Sine				Function	Check bandwidth	
▶ 4		5080A Scope	Leveled Sine				Operator Prompt	At 200 MHz, does the scope read > 70 mV?	
5							Run-Time Control		
6							Store reading as offset	<input type="checkbox"/>	
7							Apply offset to reading	<input type="checkbox"/>	
8							No evaluation performed	<input type="checkbox"/>	
9									
10									

gji69.bmp

Figure A-10. Bandwidth Test at 100 MHz

A bandwidth measurement is almost always a two step procedure. Step 1 sets a reference. Step 2 makes sure the bandwidth is equal to or wider than the specification.

Some oscilloscopes do not set a reference. In this type of test, a signal is output to the oscilloscope and the technician answers a question. For this example, the question is, "Was the reading ≥ 70 mV?" The Fluke 199C Scopemeter checks bandwidth this way.

The test procedure shown in Figure A-11 is an example that sets a signal source and then uses a manual test to see if the measurement is in specification.

	Description	Test Type	Test Mode	Test Value Expected Value	Lower Limit	Upper Limit	Auxiliary Settings	
1							Amplitude - Vpp	100.0 m
▶ 2		5080A Scope	Leveled Sine				Frequency	200 M
3		Manual Test	Text (Y = Pass)	Is the reading ≥ 70 mV?			Function	Source
4							Operator Prompt	After the UUT has settled, note the reading and click OK.
5							Run-Time Control	
6							Store reading as offset	<input type="checkbox"/>
7							Apply offset to reading	<input type="checkbox"/>
8							No evaluation performed	<input type="checkbox"/>
9								
10								

gji70.bmp

Figure A-11. Bandwidth Test with Manual Entry

Horizontal Timing Accuracy

To make sure the oscilloscope measures accurately, the scope time base accuracy must be measured. This is done with the 5080A Marker function.

The marker timing is set to supply one cycle per scope division. The marker deviation control of the generator is adjusted to align the markers to the vertical graticule line on the oscilloscope display. Do this operation again for each time base time/division setting. The image in Figure A-12 shows the marker signal lined up with the vertical lines on the graticule.

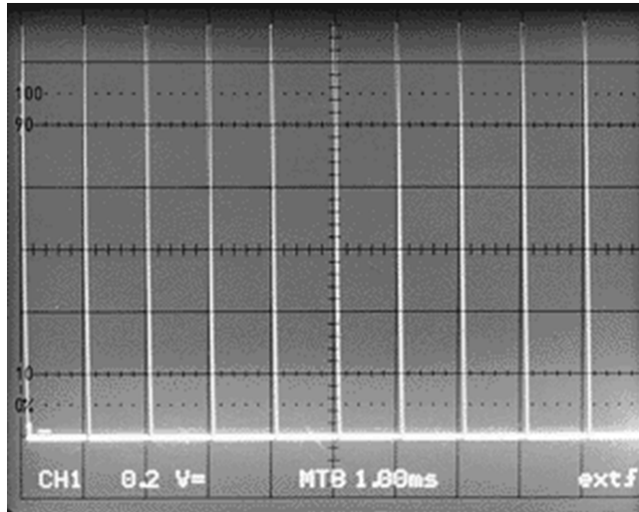

gji75.bmp

Figure A-12. Horizontal Timing Accuracy Display

Reference Material

Fluke and Tektronix offer excellent material on the calibration of oscilloscopes. Some of the material is somewhat outdated, but still valuable. These application notes can be found through an internet search.

Using the Fluke 5500A Oscilloscope Calibration Option

Oscilloscope Calibration. A guide to Oscilloscope Calibration using dedicated or multiproduct Calibrators

Appendix B

Megohm Calibration

Introduction

When the Megohm Calibration option (5080A/MEG) is installed in the 5080A, you can calibrate many different types and models of electrical testers. The Calibration Software does semi-automatic calibration of:

- Insulation resistance testers
- Continuity testers and earth (ground) resistance testers
- Loop/line impedance testers and ground bond testers
- Residual-current device (RCD) or ground fault current interrupter (GFCI) testers
Leakage current testers
- Hipot testers
- Medical safety testers

Table B-1 shows the Megohm functions.

Table B-1. Megohm Functions

Function	Description
Hi Voltage Ohm Source	Sources a resistance from 10 k Ω to 10.05 G Ω for testing leakage testers. The maximum test voltage is 1575 Vdc
Hi Voltage 18 G Ω Source	Sources a fixed 18 G Ω resistor for testing leakage testers. The maximum test voltage is 1575 Vdc
Short Circuit Current measurement	Measures the short circuit current on items like Megohm meters
Ohm Multiplier	Used with an external, optional resistance Multiplier to source resistance values from 350 M Ω to 3.5 T Ω
Low Voltage Ohm Source	Sources 16 fixed resistor values from 1 Ω to 5.9 K Ω .
Safety Test Procedure Generator	Creates procedures for safety testers like the Fluke 1577 Insulation Multimeter.

Leakage Tests

To do a leakage test:

1. Click **Tools** and then point to **Procedure Designer** from the main menu or push **F8**.

2. In a new procedure row, click  on the Test Type column and then point to **5080A Megohm**.
3. Click on **High Voltage Ω Source**.
4. Type in the test specification for the device under test. See Table B-2.

Table B-2. Insulation Resistance Accuracy Test

Step	UUT Voltage Range	Calibrator Resistance Range	Calibrator Output	UUT Display Reading	
				Limit Low	Limit High
1	500 V	60.0 MΩ	0.500 MΩ	0.0	1.0
2	500 V	500 MΩ	450 MΩ	438	462
3	500 V	500 MΩ	600 MΩ	>550	>550
4	1000 V	2.0 GΩ	1.7 GΩ	1.2	2.2
5	1000 V	600 MΩ	600 MΩ	586	614
1587 Only					
6	1000 V	60.0 MΩ	1 MΩ	0.5	1.5
7	50 V	6.00 MΩ	100 kΩ	0.05	0.15
8	50 V	50.0 MΩ	45 MΩ	43.1	46.9
9	100 V	6.00 MΩ	100 kΩ	0.05	0.15
10	100 V	100 MΩ	95 MΩ	87	103
11	250 V	60.0 MΩ	250 kΩ	0.0	0.8
12	250 V	250 MΩ	225 MΩ	217	233

An example test procedure for a Fluke 1577 is shown in Figure B-1.

	Description	Test Type	Test Mode	Test Value	Expected Value	
▶ 15		Message	Connect the model 1577 Insulation terminals to the MEGOHM terminals Press the 1577 Range button and select 500V			
16	Leakage at 500 V	5080A Megohm	Hi Voltage Ω Source	0.5M	0.0	1.0
17		5080A Megohm	Hi Voltage Ω Source	450M	438	462
18		5080A Megohm	Hi Voltage Ω Source	600M	550	800
19						
20		Message	Press the 1577 Range button and select 1000V			
21	Leakage at 1000 V	5080A Megohm	Hi Voltage Ω Source	1.7G	1.2	2.2
22		5080A Megohm	Hi Voltage Ω Source	600M	586	614

Figure B-1. Fluke 1577 Calibration Procedure

gji79.bmp

When you start the procedure, connection and setup messages are shown first. At the start of each test, the operator is instructed to click OK when the Test button in the item being calibrated has been pressed, and then release it when the reading is stable. While the button is pushed, the Calibration Software gets the 1577 source voltage measured by the 5080A. When the button is released, the UUT leakage resistance is read from the 1577 display and typed into the Calibration Software.

The High Voltage 18 GΩ Source test is setup the same way, except that the resistance value is fixed at 18 GΩ.

Short Circuit Tests

A Short Circuit test is usually used in a Megohm meter calibration. Many meters have a short circuit current specification. Usually this is in the low mA range. Figure B-2 shows an example of a Short Circuit test.

Message	Set the meter to the 10K Ohm range			
5080A Megohm	Short Circuit Current	1.5m	1.0	2.0

Figure B-2. Short Circuit Test Steps

gji80.bmp

High Resistance values

High resistance values from 350 MΩ to 3.5 TΩ can be sourced by the 5080A in combination with a Resistance Multiplier. The 5080A manual has data on this accessory and how it is connected to the 5080A and the device under test.

To make a resistance value in the 350 MΩ to 3.5 TΩ range, select the Ω Multiplier Test Mode, and enter the needed test values. Figure B-3 shows an example of a High value resistance procedure step.

Test Type	Test Mode	Test Value	Expected Value	
Message	Connect the Ohms multiplier between the 5080A and the UUT			
5080A Megohm	Ω Multiplier	400M	360.0	440.0

Figure B-3. High Resistance Values Calibration Steps

gji81.bmp

Low Voltage Ohm Source

This mode sources 16 fixed resistor values from 1 Ω to 5.9 KΩ. It is used to do standard resistance mode calibrations.

To make a low value resistance, set the Low Voltage Ω Source test mode and then click the button in the Text Value cell. Next, select a resistor value from the drop down resistor list and select if the item being calibrated will display the reading in ohms or k ohms. Figure B-4 shows an example of a Low Voltage Ω Source procedure step.

Test Type	Test Mode	Test Value	Expected Value	
Message	Connect the UUT to the MEGOHM terminals			
5080A Megohm	Low Voltage Ω Source	5.9 K	5.841	5.959

Figure B-4. Low Voltage Ohm Source Calibration Steps

gji82.bmp

Appendix C

Database Fields

Tables C-1 through C-3 show the data fields that can be used in reports.

Table C-1. Inventory Data Fields

Column Name	Data Type	Length
AssetNumber	char	100
Manufacturer	char	100
Model	char	100
Description	char	100
SerialNumber	char	100
CalibrationInterval	int	
IntervalUnits	char	1
UserName	char	100
UserDepartment	char	100
UserPhone	char	100
UserEmail	char	100
InventoryNotes	char	1000

Table C-2. Calibration Data Fields

Column Name	Data Type	Length
CalibrationDate	datetime	
DueDate	datetime	
CurrentRecord	bit	
CalibrationPassed	bit	

Table C-2. Calibration Data Fields (cont.)

Column Name	Data Type	Length
ElapsedTimeMinutes	int	
TechnicianName	char	100
CertificateNumber	char	100
CalibrationProcedure	char	100
CalibrationRegulation	char	100
Temperature	numeric	
Humidity	tinyint	
CalibrationNotes	char	1000

Table C-3. Results Data Fields

Column Name	Data Type	Length
Row	int	
Description	char	100
TestType	char	100
TestMode	char	100
Signal_1	char	100
Signal_2	char	100
Frequency	char	20
PA_PF	char	10
Coil	char	3
Nominal	char	100
Actual	char	100
UUTReading	char	100
LowerLimit	char	100
UpperLimit	char	100
Pass	bit	
Deviation	char	100
Error	char	100
PctOfTol	char	100

Appendix D Results Table

When the 5080A calibrator is used to run a procedure, data is gathered at each test step. When all the steps are finished, the data is written to the database. Table D-1 is an example of how the Calibration Software populates the results table for each type of test.

Table D-1. Test Results

Row	Desc	Test Type	Test Mode	Aux 1	Aux 2	Freq	PA PF	Coil	Nominal	Actual	UUT Reading	Lower Limit	Upper Limit
1	DMM	5080A V-Ω-A	DC Volts						2 V	2.0 V	2.0 V	1 V	3 V
2		5080A V-Ω-A	AC Volts			60 Hz			2 V	2.0 V	2.0 V	1 V	3 V
3		5080A V-Ω-A	DC Amps						2 A	2.0 A	2.0 A	1 A	3 A
4		5080A V-Ω-A	AC Amps			60 Hz			2 A	2.0 A	2.0 A	1 A	3 A
6	Offset applied	5080A V-Ω-A	Fixed Ohms						10.0 Ω	10 Ω	10 Ω	9.8 Ω	10.2 Ω
7													
8	Scope	5080A Scope	Vertical	1 MΩ		1000 Hz			20mVp-p	4.0 Div	4.0 Div	3.88 Div	4.12 Div
10		5080A Scope	Rise Time	25.0 mV		1.0 MHz			2.24 ns	2.24 ns	2.0 ns		0.0
10		5080A Scope	Rise Time	25.0 mV		1.0 MHz			2.24 ns	2.24 ns	2.0 ns		0.0
12	Bandwidth	5080A Scope	Leveled Sine			100 MHz			Is amplitude > 4.2 divisions?		Yes		
13													
14	Time mark	5080A Scope	Time Mark	1 ms					1 ms	0.99 ms	1.0 ms	0.96	1.04
16	Power	5080A Power	DC Watts	120 V	5 A			10x	600.0 W	600.0 W	600.0 W	570.0 W	630.0 W
17		5080A Power	AC Watts	120 V	10 A	60 Hz	45°		848.4 W	848.4 W	848.4 W	814.4 W	882.3 W
19	MegOhm	5080A Megohm	Hi Voltage Ω Source						10 GΩ	9.9 GΩ	10.0 GΩ	9.6 GΩ	10.4 GΩ
20		5080A Megohm	Hi Voltage 18 GΩ Source						18 GΩ	18.23 GΩ	18 GΩ	17.33 GΩ	19.13 GΩ
21		5080A Megohm	Short Circuit Current						100 μA	100.0 μA	100.0 μA	97.0 μA	103.0 μA
22		5080A Megohm	Ω Multiplier						100 GΩ	99.9 GΩ	100.0 GΩ	97.0 GΩ	103.0 GΩ
23		5080A Megohm	Low Voltage Ω Source						5.9 Ω	5.91 Ω	5.9 Ω	5.67 Ω	6.14 Ω
25	Manual Tests	Manual Test	Numeric						350.2 °K		350.0 °K	332.5 °K	367.5 °K
26		Manual Test	Text (Y = Pass)						Did the high-temp light go on?		Yes		
27		Manual Test	Text (Y = Pass)						Did the oven door lock?		Yes		

Table D-2 describes the Test Results Columns:

Table 2. Column Descriptions for Test Results Table

Column Name	Description
Row Number	The row number is automatically assigned by the Calibration Software.
Description (Desc)	The Description column is an option and is generally used to clarify reports and to indicate what is being tested.
Test Type and Test Mode	List the major and minor test category.
Aux 1 and Aux 2	The Aux 1 and Aux 2 columns are additional information about a test. The information is a function of the Test type and Test Mode.
Frequency(Freq)	Indicates the frequency of the test signal.
PF/PA	Indicates the Power Factor or Phase Angle of AC Power tests.
Coil	Shows the number of coil turns if a coil is used for DC and AC current tests.
Nominal, Actual, Limits, UUT Reading, Deviation, Error and % of Tolerance	These columns list the readings.

When writing calibration certificate reports, these result columns can be used to best describe the test performed. If possible, different calibration reports can be written for different types of devices. The report would use different results columns for each type of item. For example, a lab may have a DMM, Oscilloscope and Wattmeter report.